



M+S HYDRAULIC

HYDRAULIC MOTORS

**MLHS
MLHT
MLHV**



SAE version

DISC VALVE HYDRAULIC MOTORS

CONTENTS

	Page
● Hydraulic Motors Series MLHS	4
● Hydraulic Motors Series MLHT	25
● Hydraulic Motors Series MLHV	39
● Motor Special Features.....	51
● Motors with Speed Sensor.....	52
● Application Calculation	54

DISC VALVE HYDRAULIC MOTORS

GENERAL INFORMATION:

Orbit motors convert hydraulic energy (pressure, oil flow) into mechanical energy (torque, speed). Hydraulic orbit motors operate on the principle of an internal gear (rotor) rotating within a fixed external gear (stator). The internal gear transmits the torque generated by the application of pressure from hydraulic oil fed into motor which is then delivered via the motor's output shaft. Orbit motors have high starting torque and constant output torque at wide speed range. The output shaft runs on tapered roller bearings and can absorb high axial and radial forces.

DISTRIBUTOR VALVE

MLHS, MLHT, MLHV series motors has disk valve: the distributor valve has been separated from output shaft and is driven by short cardan shaft. A balance plate counterbalances the hydraulic forces around the distributor valve. It gives the motors high efficiency- even at high pressures, and good starting characteristics.

GEAR WHEEL SET

There are two forms of gear wheel set: Gerotor set have plain teeth and Roll-gerotor set with teeth fitted with rollers. MLHS, MLHT, MLHV series motors have roll-gerotor set. The rollers reduce local stress and the tangential reaction forces on the rotor reducing friction to a minimum. This gives long operating life and better efficiency even at continuous high pressures.

FEATURES:

Standard Motor

The standard motor mounting flange is located as close to the output shaft as possible. This type of mounting supports the motor close to the shaft load. This mounting flange is also compatible with many standard gear boxes.

Wheel Motor

The wheel motor mounting flange is located near the center of the motor which permits part or all of the motor to be located inside the wheel or roller hub. In traction drive applications, loads can be positioned over the motor bearings for best bearing life. This wheel motor mounting flange provides design flexibility in many applications.

Short Motor

This motor is assembled without the output shaft, bearings and bearing housing and has the same drive components as the standard motors. The short motor is especially suited for applications such as gear boxes, winch, reel and roll drives. Short motor applications must be designed with a bearing supported internal spline to mate with the short motor drive. Product designs using these hydraulic motors provide considerable cost savings.

Low Leakage

LL Series hydraulic motors are designed to operate at the whole standard range of working conditions (pressure drop and frequency of rotation), but with considerable decreased volumetric losses in the drain ports. This motors are suitable for hydraulic systems with series-connected motors with demands for low leakage.

Low Speed Valve

LSV feature optimizes the motor for low-speed performance. Motors with this valving provide very low speed while maintaining high torque. They are designed to run continuously at low speed (up to 200 RPM) at normal pressure drop and reduced flow. Optimal run is guaranteed at frequency of rotation from 20 to 50 RPM. Motors with this valving have an increased starting pressure and are not recommended for using at pressure drop less than 580 PSI [40 bar].

High Pressure Shaft Seal

The high pressure shaft seals allow the motors to withstand high case pressures at high speeds without external drain line.

Motors with Speed Sensor

Motors are available with integrated inductive speed sensor. The output signal is a standardized voltage signal that can be used to control the speed of a motor. The torque and the radial load of the motor are not affected by the installation of speed sensor.

HYDRAULIC MOTORS MLHS



APPLICATION

- » Conveyors
- » Metal working machines
- » Agricultural machines
- » Road building machines
- » Mining machinery
- » Food industries
- » Special vehicles etc.

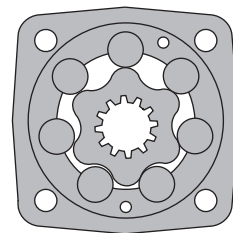
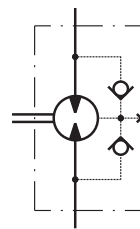

CONTENTS

Specification data	5÷6
Performance data	7÷12
Permissible shaft seal pressure.....	12
Dimensions and mounting	13÷15
Dimensions and mounting - ports	16
Tacho connection	16
Motor with Drum brake- MLHSBD	17
Shaft extensions	18
Permissible shaft loads	19
Function diagram for MLHSBD.....	19
Dimensions and mounting- MLHSS, Z, V, U... ..	20÷21
Dimensions of the attached component	22÷23
Internal Spline data	24
Order code	24

OPTIONS

- » Model - Disc valve, roll-gerotor
- » Flange and wheel mount
- » Short motor
- » Motor with Drum Brake
- » Tacho connection
- » Speed sensing
- » Side and rear ports
- » Shafts- straight, splined and tapered
- » SAE, Metric and BSPP ports
- » Other special features

GENERAL

Max. Displacement, in ³ /rev [cm ³ /rev]	34.47 [564,9]
Max. Speed, [RPM]	1000
Max. Torque, lb-in [daNm]	cont.: 7520 [85] int.: 8760 [99]
Max. Output, HP [kW]	30.8 [23]
Max. Pressure Drop, PSI [bar]	cont.: 3050 [210] int.: 3990 [275]
Max. Oil Flow, GPM [lpm]	24 [90]
Min. Speed, [RPM]	5
Permissible Shaft Loads lbs [daN]	P _a =1125 [500]
Pressure fluid	Mineral based- HLP(DIN 51524) or HM(ISO 6743/4)
Temperature range, °F [°C]	-40÷284 [-40÷140]
Optimal Viscosity range, SUS [mm ² /s]	98÷347 [20÷75]
Filtration	ISO code 20/16 (Min. recommended fluid filtration of 25 microns)

Oil flow in drain line

Pressure drop PSI [bar]	Viscosity SUS [mm ² /s]	Oil flow in drain line GPM [lpm]
2030 [140]	98 [20]	.396 [1,5]
	164 [35]	.264 [1]
3045 [210]	98 [20]	.793 [3]
	164 [35]	.528 [2]

Pressure Losses

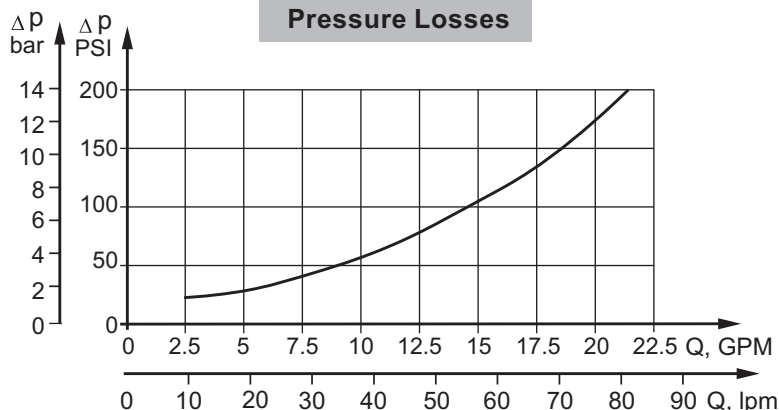

SPECIFICATION DATA

Type		MLHS 80	MLHS 100	MLHS 125	MLHS 160	MLHS 200
Displacement, in³/rev [cm³/rev]		4.91 [80,5]	6.1 [100]	7.67 [125,7]	9.74 [159,7]	12.2 [200]
Max. Speed, [RPM]	cont.	810	750	600	470	375
	Int.*	1000	900	720	560	450
Max. Torque lb-in [daNm]	cont.	2120 [24]	2700 [30,5]	3320 [37,5]	4340 [49]	5400 [61]
	Int.*	2740 [31]	3450 [39]	4340 [49]	5310 [60]	6370 [72]
Max. Output HP [kW]	cont.	20.8 [15,5]	24.1 [18]	24.1 [18]	22.1 [16,5]	22.1 [16,5]
	int.*	26.2 [19,5]	30.2 [22,8]	30.2 [22,5]	30.8 [23]	29.52 [22]
Max. Pressure Drop PSI [bar]	cont.	3050 [210]	3050 [210]	3050 [210]	3050 [210]	3050 [210]
	Int.*	3990 [275]	3990 [275]	3990 [275]	3990 [275]	3990 [275]
	peak**	4280 [295]	4280 [295]	4280 [295]	4280 [295]	4280 [295]
Max. Oil Flow GPM [lpm]	cont.	17 [65]	20 [75]	20 [75]	20 [75]	20 [75]
	Int.*	21 [80]	24 [90]	24 [90]	24 [90]	24 [90]
Max. Inlet Pressure PSI [bar]	cont.	3340 [230]	3340 [230]	3340 [230]	3340 [230]	3340 [230]
	Int.*	4280 [295]	4280 [295]	4280 [295]	4280 [295]	4280 [295]
	peak**	4350 [300]	4350 [300]	4350 [300]	4350 [300]	4350 [300]
Max. Return Pressure with Drain Line PSI [bar]	cont.	2030 [140]	2030 [140]	2030 [140]	2030 [140]	2030 [140]
	Int.*	2540 [175]	2540 [175]	2540 [175]	2540 [175]	2540 [175]
	peak**	3050 [210]	3050 [210]	3050 [210]	3050 [210]	3050 [210]
Max. Starting Pressure with Unloaded Shaft, PSI [bar]		175 [12]	145 [10]	145 [10]	115 [8]	115 [8]
Min. Starting Torque lb-in [daNm]	at max. press. drop cont.	1590 [18]	2040 [23]	2570 [29]	3270 [37]	4160 [47]
	at max. press. drop Int.*	2080 [23,5]	2660 [30]	3360 [38]	4070 [46]	4960 [56]
Min. Speed***, [RPM]		10	10	8	8	6
Weight, lb [kg] For Rear Ports + .88[0,40]	MLHS(F)	21.8 [9,9]	22.2 [10,1]	22.9 [10,4]	23.8 [10,8]	24.7 [11,2]
	MLHSB	22.9 [10,4]	23.3 [10,6]	24 [10,9]	24.6 [11,3]	25.8 [11,7]
	MLHSS(Z)	17.4 [7,9]	17.8 [8,1]	18.5 [8,4]	19.4 [8,8]	20.2 [9,2]
	MLHSV	12.8 [5,8]	13.2 [6]	13.9 [6,3]	14.8 [6,7]	15.6 [7,1]
	MLHSW(E)	22.7 [10,3]	23.2 [10,5]	23.8 [10,8]	24.7 [11,2]	25.6 [11,6]
	MLHSBD	37.3 [16,9]	37.7 [17,1]	38.3 [17,4]	39.2 [17,8]	41.1 [18,2]

* Intermittent operation: the permissible values may occur for max. 10% of every minute.

** Peak load: the permissible values may occur for max. 1% of every minute.

*** For speeds lower than given, consult factory or your regional manager.

1. Intermittent speed and intermittent pressure drop must not occur simultaneously.
2. Recommended filtration is per ISO cleanliness code 20/16. A nominal filtration of 25 micron or better.
3. Recommend using a premium quality, anti-wear type mineral based hydraulic oil HLP(DIN51524) or HM (ISO 6743/4).
If using synthetic fluids consult the factory for alternative seal materials.
4. Recommended minimum oil viscosity 70 SUS [13 mm²/s] at 122°F [50°C].
5. Recommended maximum system operating temperature is 180°F [82°C].
6. To assure optimum motor life fill with fluid prior to loading and run at moderate load and speed for 10-15 minutes.

SPECIFICATION DATA (continued)

Type		MLHS 250	MLHS 315	MLHS 400	MLHS 475	MLHS 525	MLHS 565
Displacement, in³/rev [cm³/rev]		15.3 [250]	19.2 [314,9]	24.2 [397]	28.96[474,6]	31.88 [522,7]	34.47[564,9]
Max. Speed, [RPM]	cont.	300	240	190	160	145	130
	Int.*	360	290	230	190	175	160
Max. Torque lb-in [daNm]	cont.	6370 [72]	7300 [82,5]	7660 [86,5]	7520 [85]	7520 [85]	7520 [85]
	Int.*	7700 [87]	8850 [100]	8760 [99]	8760 [99]	8760 [99]	8760 [99]
Max. Output HP [kW]	cont.	19.4 [14,5]	20.1 [15]	14.8 [11]	11 [8,4]	10.2 [7,6]	9 [6,9]
	int.*	24.1 [18]	22.8 [17]	16.8 [12,5]	15 [11,3]	13.9 [10,4]	13 [9,6]
Max. Pressure Drop PSI [bar]	cont.	2900 [200]	2900 [200]	2320 [160]	1880 [130]	1670 [115]	1520 [105]
	Int.*	3630 [250]	3480 [240]	2760 [190]	2180 [150]	1960 [135]	1810 [125]
	peak**	3920 [270]	3770 [260]	3050 [210]	2470 [170]	2250 [155]	2100 [145]
Max. Oil Flow GPM [lpm]	cont.	20 [75]	20 [75]	20 [75]	20 [75]	20 [75]	20 [75]
	Int.*	24 [90]	24 [90]	24 [90]	24 [90]	24 [90]	24 [90]
Max. Inlet Pressure PSI [bar]	cont.	3340 [230]	3340 [230]	3340 [230]	3340 [230]	3340 [230]	3340 [230]
	Int.*	4280 [295]	4280 [295]	4280 [295]	4280 [295]	4280 [295]	4280 [295]
	peak**	4350 [300]	4350 [300]	4350 [300]	4350 [300]	4350 [300]	4350 [300]
Max. Return Pressure with Drain Line PSI [bar]	cont.	2030 [140]	2030 [140]	2030 [140]	2030 [140]	2030 [140]	2030 [140]
	Int.*	2540 [175]	2540 [175]	2540 [175]	2540 [175]	2540 [175]	2540 [175]
	peak**	3050 [210]	3050 [210]	3050 [210]	3050 [210]	3050 [210]	3050 [210]
Max. Starting Pressure with Unloaded Shaft, PSI [bar]		115 [8]	115 [8]	115 [8]	115 [8]	115 [8]	115 [8]
Min. Starting Torque lb-in [daNm]	at max. press. drop cont.	4960 [56]	6280 [71]	6280 [71]	6280 [71]	6280 [71]	6280 [71]
	at max. press. drop Int.*	6200 [70]	7520 [85]	7430 [84]	7430 [84]	7430 [84]	7430 [84]
Min. Speed***, [RPM]		6	5	5	5	5	5
Weight, lb [kg] For Rear Ports + .88[0,40]	MLHS(F)	25.8 [11,7]	27.3 [12,4]	29.3 [13,1]	31 [14,1]	32.2 [14,6]	33.1 [15]
	MLHSB	26.9 [12,2]	28.4 [12,9]	30.4 [13,8]	32.2 [14,6]	33.3 [15,1]	34.1 [15,5]
	MLHSS(Z)	21.4 [9,7]	22.9 [10,4]	24.9 [11,3]	26.7 [12.1]	27.8 [12,6]	28.6 [13]
	MLHSV	16.7 [7,6]	18.3 [8,3]	20.2 [9,2]	22 [10]	23.1 [10,5]	24 [10,9]
	MLHSW(E)	26.7 [12,1]	28.2 [12,8]	30.2 [13,7]	32 [14,5]	33.1 [15]	33.9 [15,4]
	MLHSBD	41.2 [18,7]	42.7 [19,4]	44.7 [20,3]	46.5 [21,1]	47.6 [21,6]	48.5 [23]

* Intermittent operation: the permissible values may occur for max. 10% of every minute.

** Peak load: the permissible values may occur for max. 1% of every minute.

*** For speeds lower than given, consult factory or your regional manager.

1. Intermittent speed and intermittent pressure drop must not occur simultaneously.
2. Recommended filtration is per ISO cleanliness code 20/16. A nominal filtration of 25 micron or better.
3. Recommend using a premium quality, anti-wear type mineral based hydraulic oil HLP(DIN51524) or HM (ISO 6743/4).
If using synthetic fluids consult the factory for alternative seal materials.
4. Recommended minimum oil viscosity 70 SUS [13 mm²/s] at 122°F [50°C].
5. Recommended maximum system operating temperature is 180°F [82°C].
6. To assure optimum motor life fill with fluid prior to loading and run at moderate load and speed for 10-15 minutes.

FUNCTION DIAGRAMS

MLHS 80

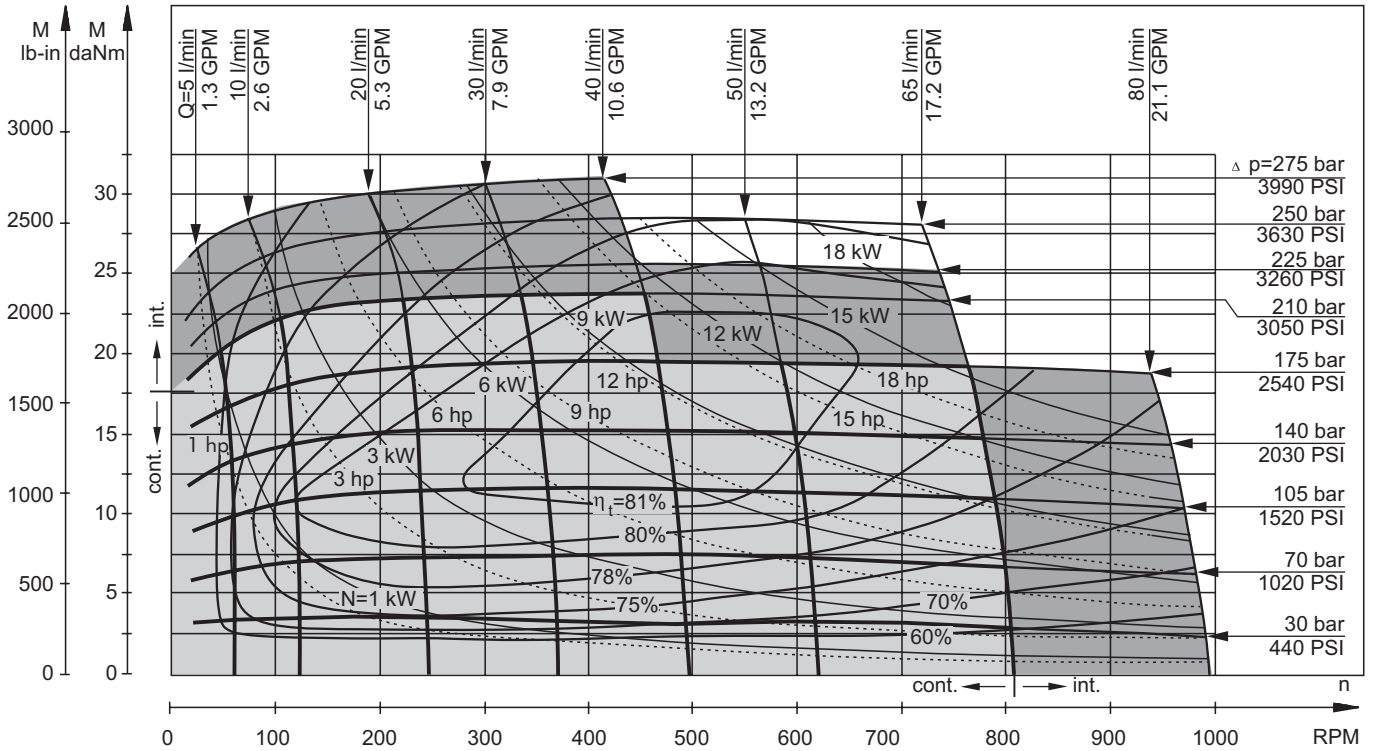

MLHS 100

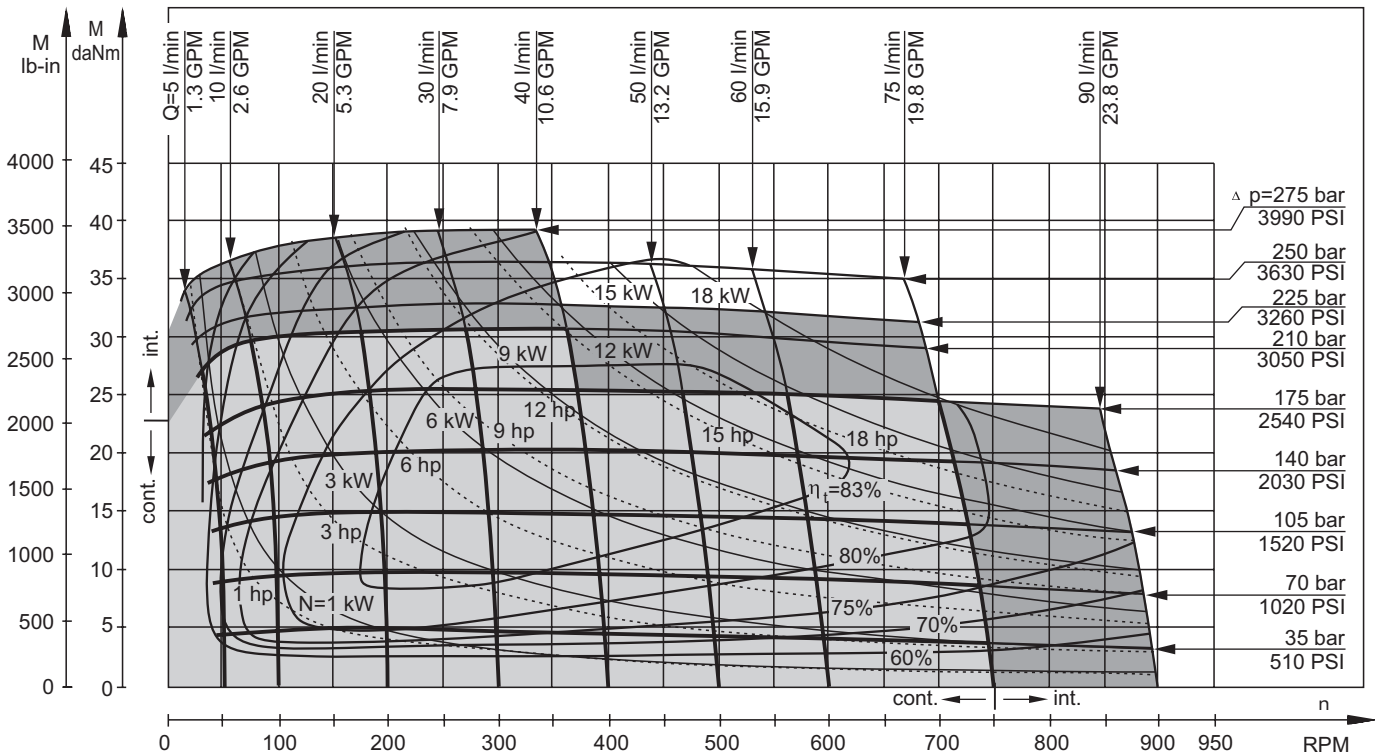

The function diagrams data is for average performance of randomly selected motors at back pressure 5÷10 bar [72.5÷145 PSI] and oil with viscosity of 32 mm²/s [150 SUS] at 50°C [122°F].

FUNCTION DIAGRAMS

MLHS 125

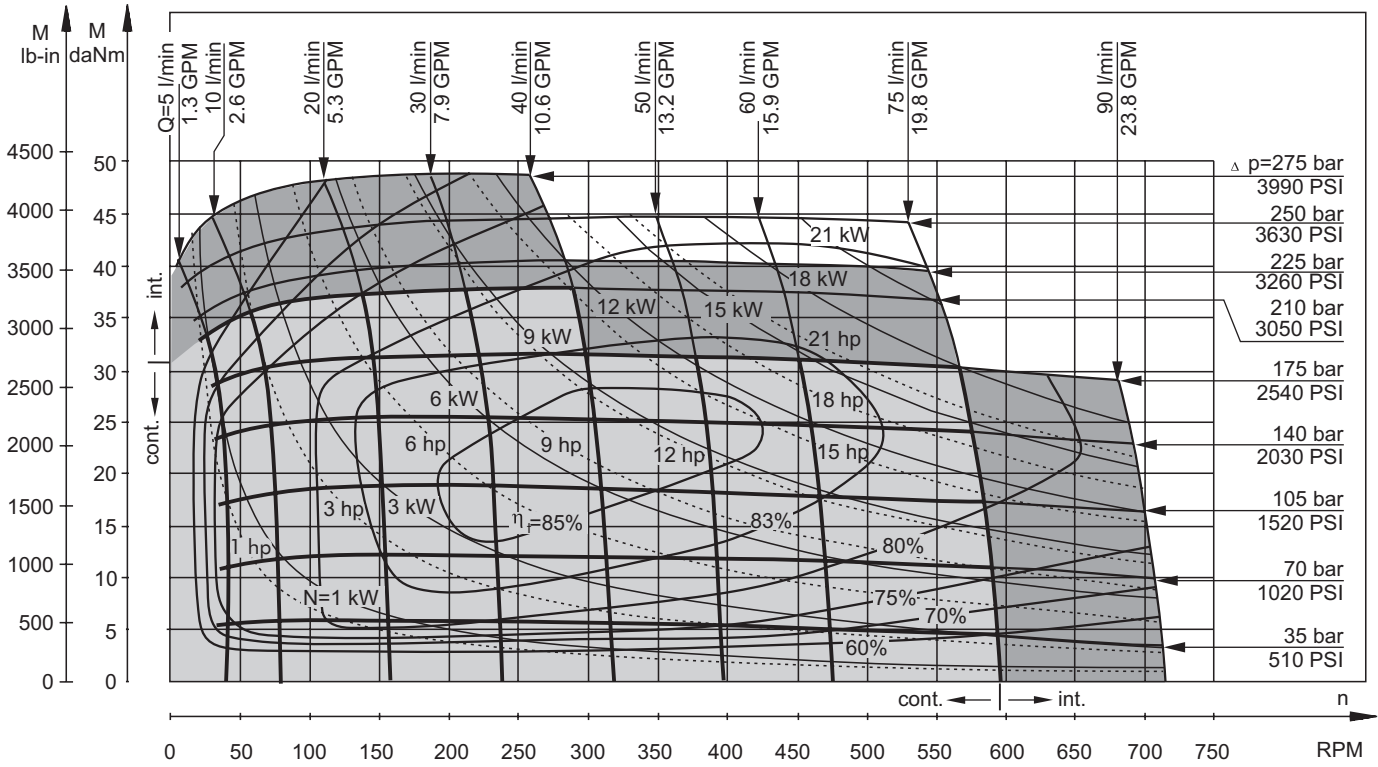

MLHS 160

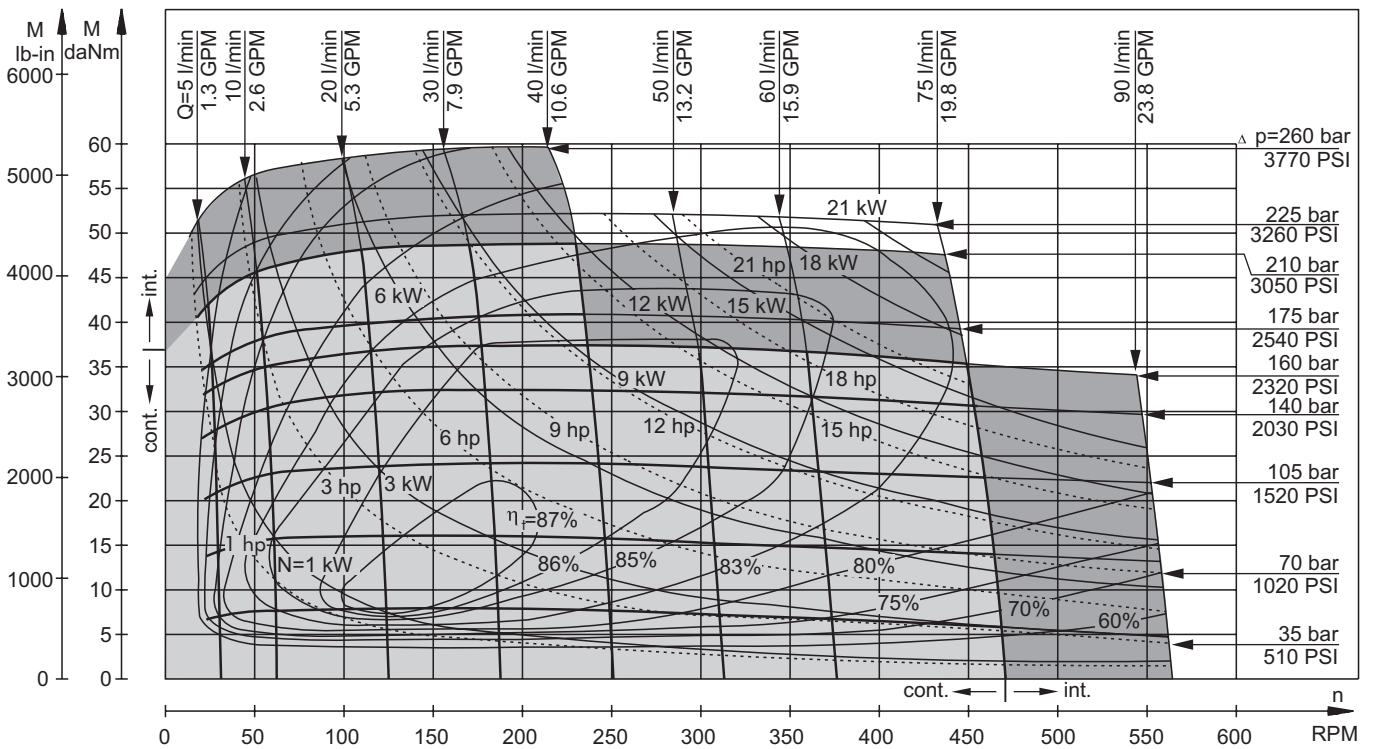

The function diagrams data is for average performance of randomly selected motors at back pressure 5±10 bar [72.5±145 PSI] and oil with viscosity of 32 mm²/s [150 SUS] at 50°C [122°F].

FUNCTION DIAGRAMS

MLHS 200

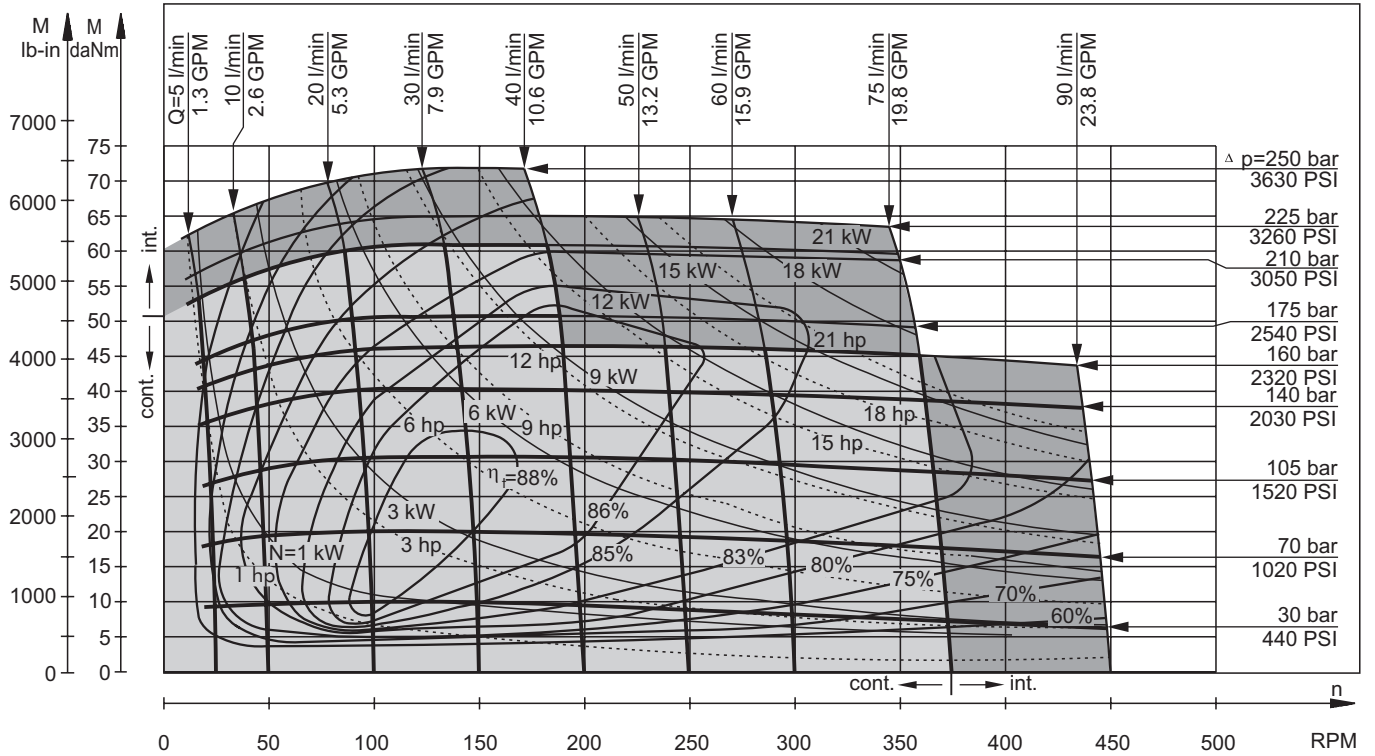

MLHS 250

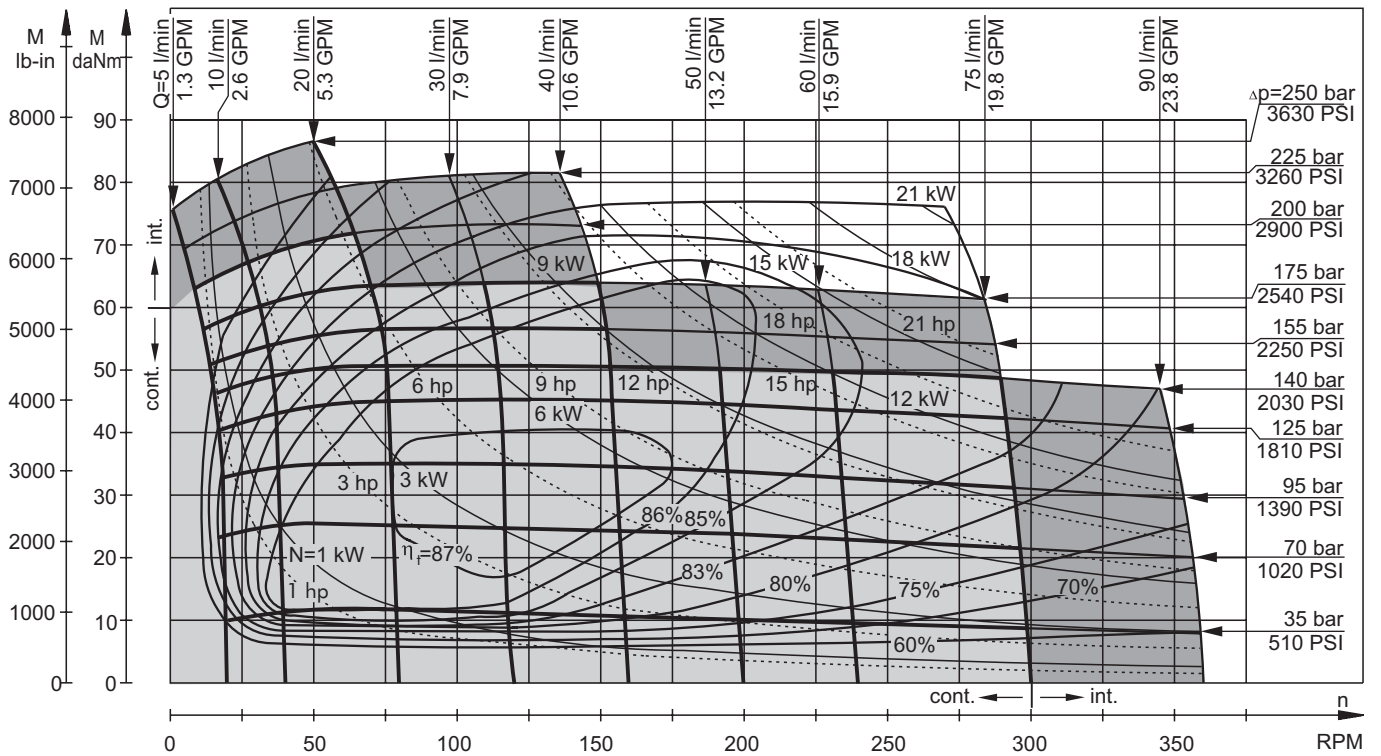

The function diagrams data is for average performance of randomly selected motors at back pressure 5÷10 bar [72.5÷145 PSI] and oil with viscosity of 32 mm²/s [150 SUS] at 50°C [122°F].

FUNCTION DIAGRAMS

MLHS 315

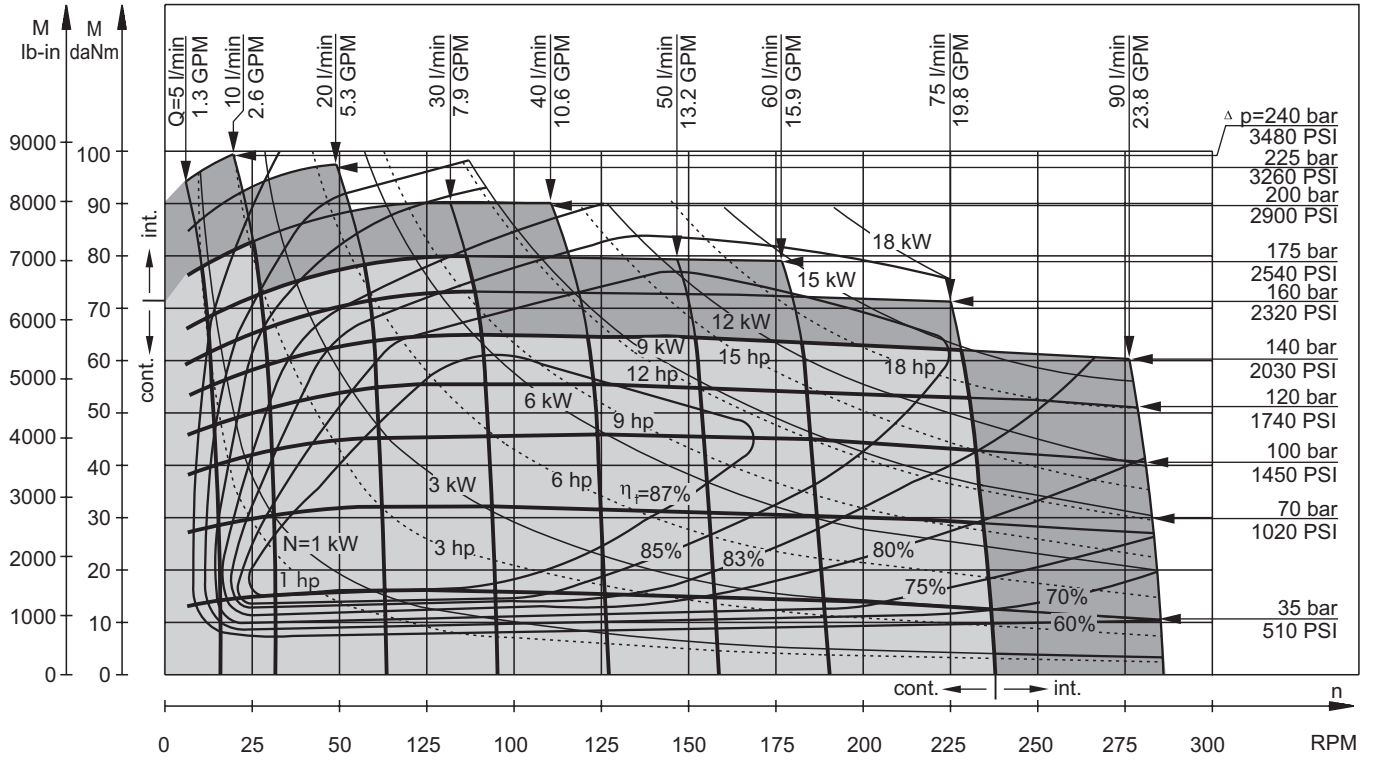

MLHS 400

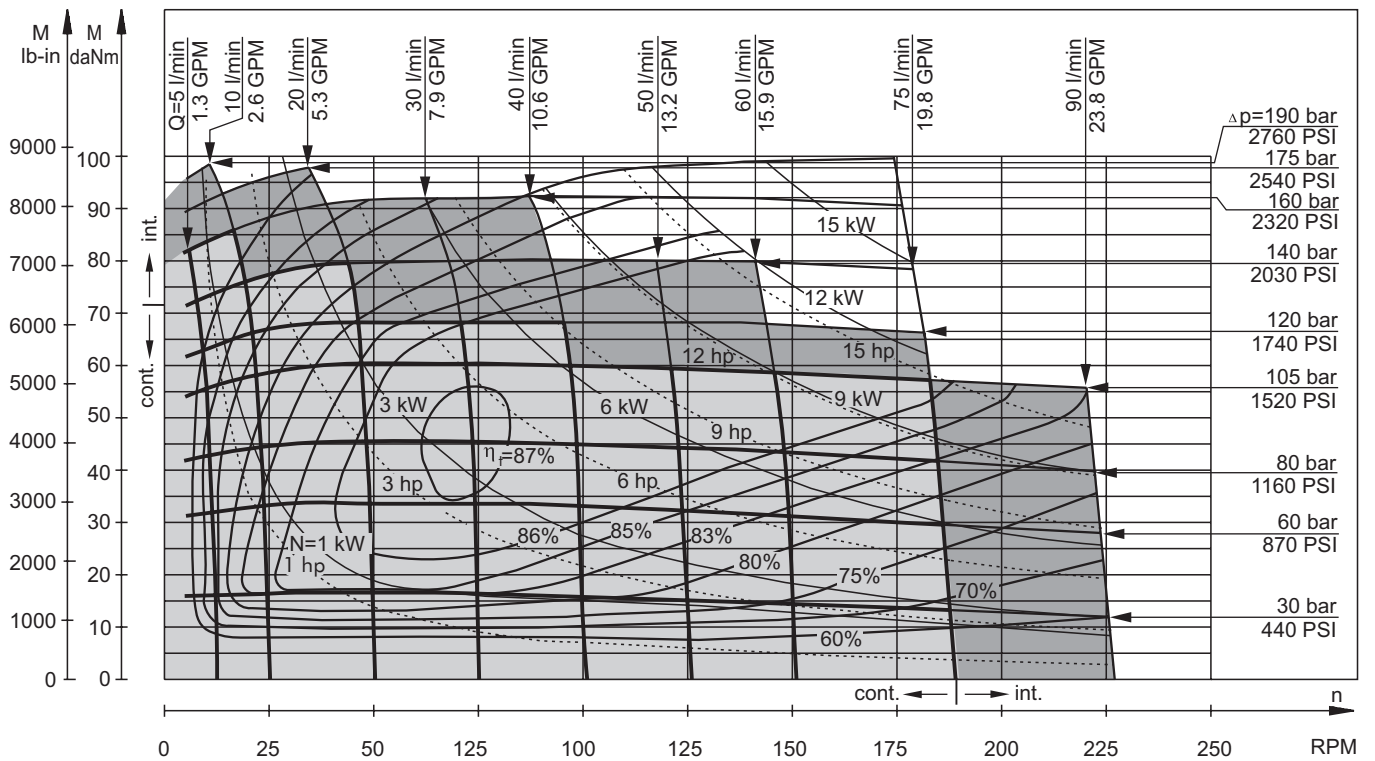

The function diagrams data is for average performance of randomly selected motors at back pressure 5÷10 bar [72.5÷145 PSI] and oil with viscosity of 32 mm²/s [150 SUS] at 50°C [122°F].

FUNCTION DIAGRAMS

MLHS 475

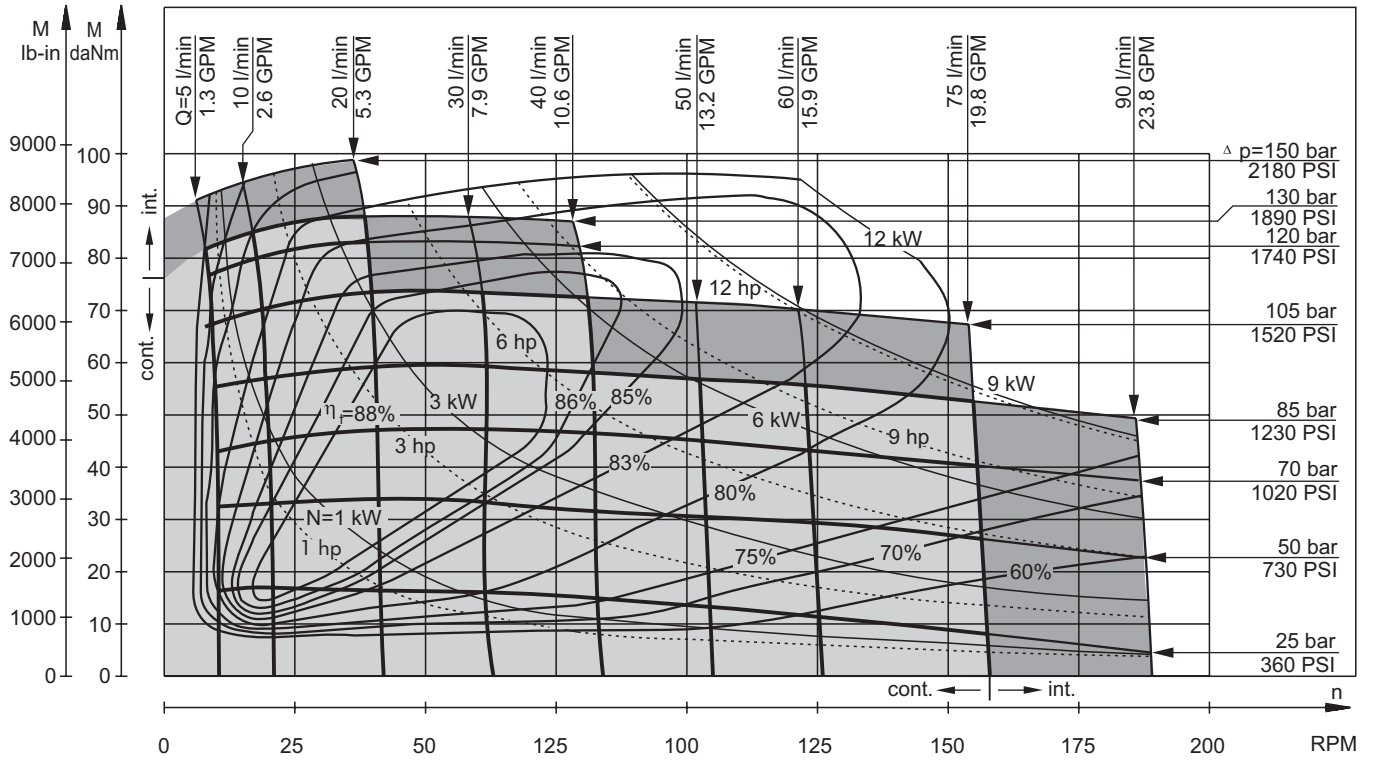

MLHS 525

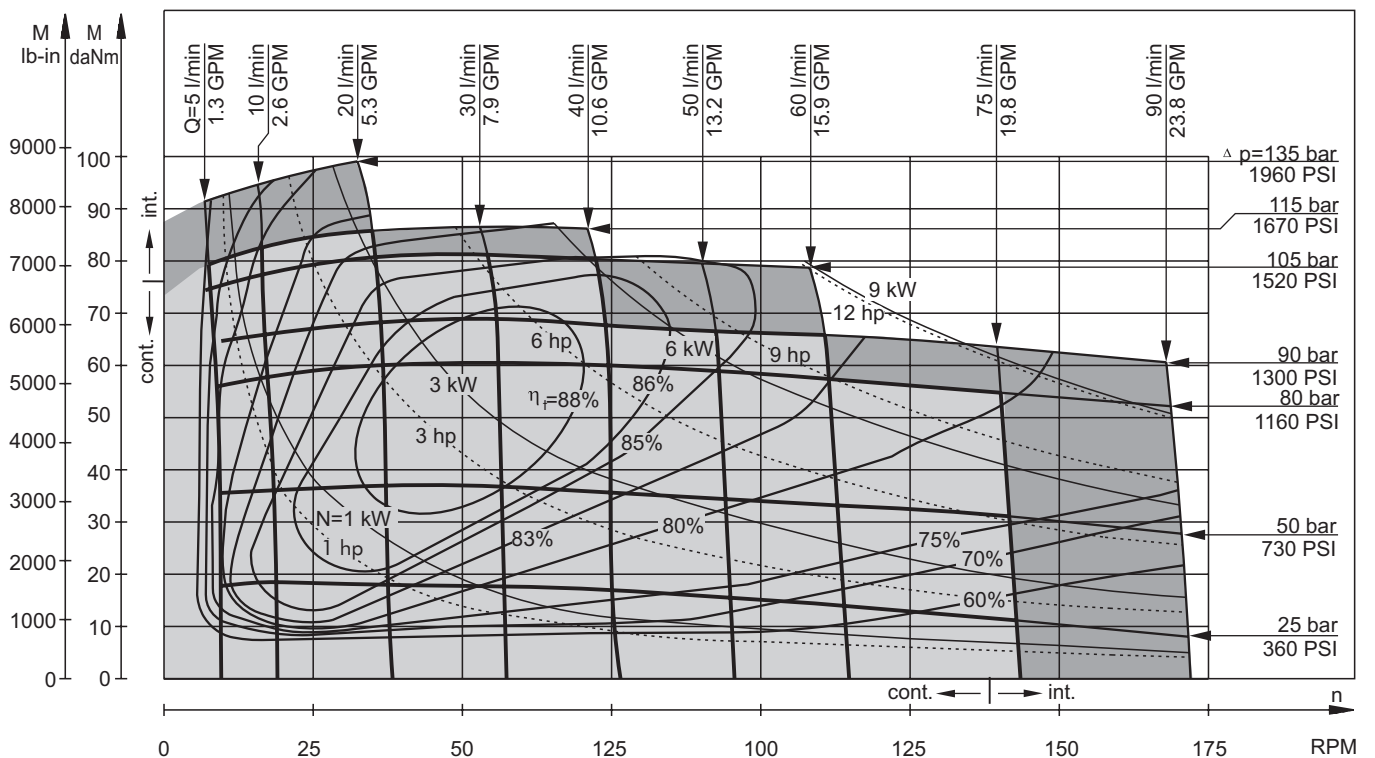

The function diagrams data is for average performance of randomly selected motors at back pressure 5÷10 bar [72.5÷145 PSI] and oil with viscosity of 32 mm²/s [150 SUS] at 50°C [122°F].

FUNCTION DIAGRAMS

MLHS 565

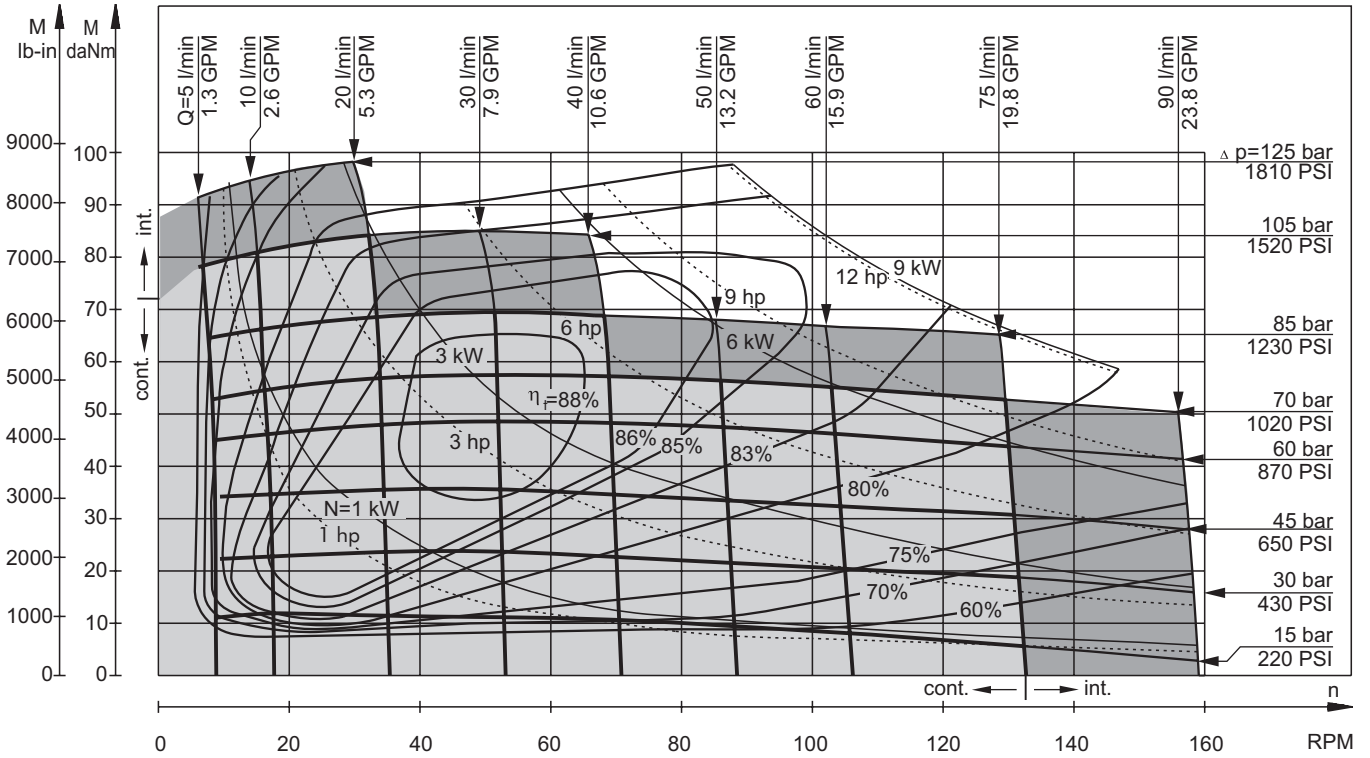

The function diagrams data is for average performance of randomly selected motors at back pressure 5÷10 bar [72.5÷145 PSI] and oil with viscosity of 32 mm²/s [150 SUS] at 50°C [122°F].

MAX. PERMISSIBLE SHAFT SEAL PRESSURE

Max. return pressure without drain line or
max. pressure in the drain line

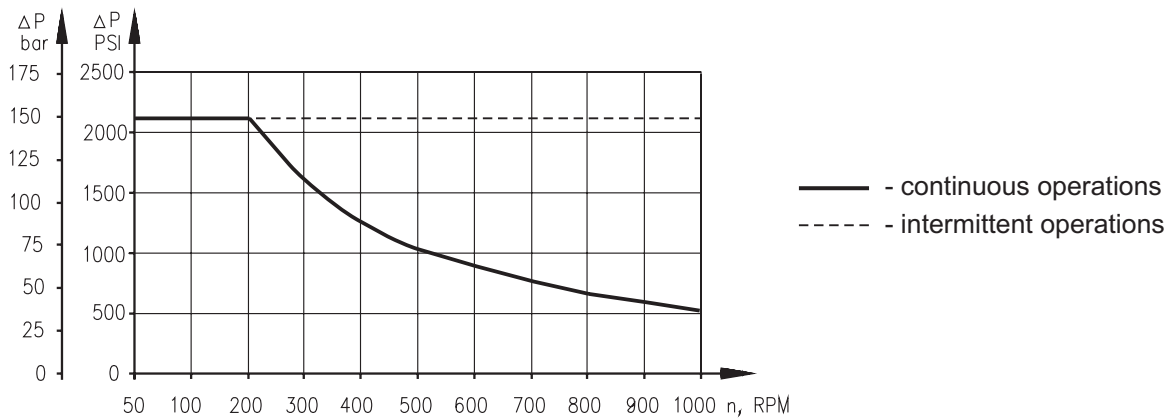

DIMENSIONS AND MOUNTING DATA

MLHS, MLHSF, MLHSA

Shaft Dim.
See Page 17

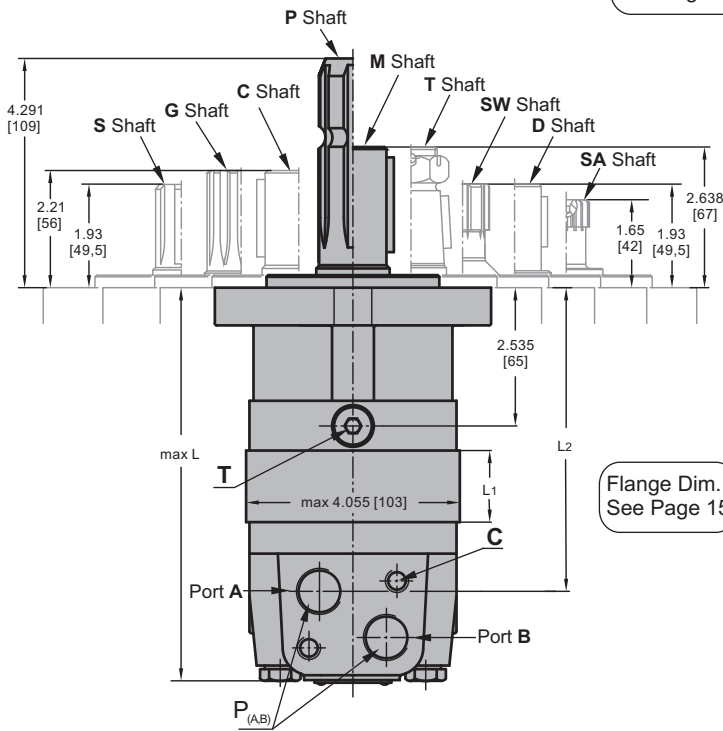

Flange Dim.
See Page 15

MLHSB

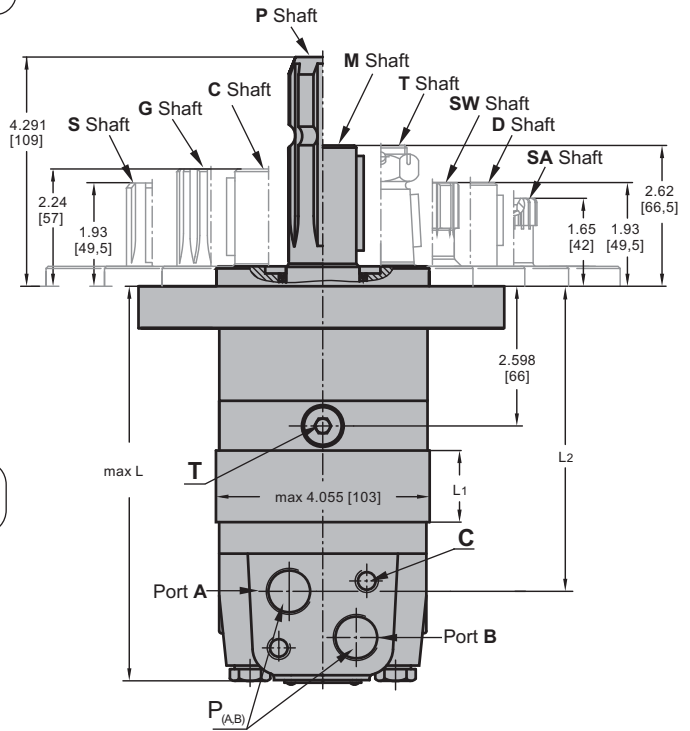

Versions **6 7 8 9**
Rear ports

Port Dim.
See Page 16

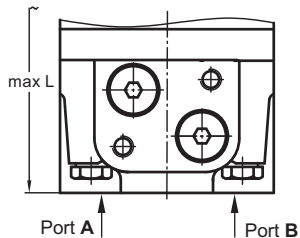

	Versions			
	2,6	3,9	4,7	5,8
C	2xM10	2xM10	2x $\frac{3}{8}$ -16UNC	2x $\frac{3}{8}$ -16UNC
P_(A,B)	2xG $\frac{1}{2}$	2xM22x1,5	2x $\frac{1}{8}$ -14UNF	2x $\frac{1}{2}$ -14NPTF
T	G $\frac{1}{4}$	M14x1,5	$\frac{1}{16}$ -20UNF	$\frac{1}{16}$ -20UNF

Type	L max, in [mm]		L1, in [mm]	L2, in [mm]
	Versions 2,3,4,5	*Versions 6,7,8,9		
MLHS(A,F,B) 80	6.61 [168]	6.89 [175]	.55 [14,0]	4.88 [124]
MLHS(A,F,B) 100	6.73 [171]	7.05 [179]	.69 [17,4]	5.04 [128]
MLHS(A,F,B) 125	6.93 [176]	7.21 [183]	.86 [21,8]	5.20 [132]
MLHS(A,F,B) 160	7.17 [182]	7.44 [189]	1.09 [27,8]	5.43 [138]
MLHS(A,F,B) 200	7.44 [189]	7.72 [196]	1.37 [34,8]	5.71 [145]
MLHS(A,F,B) 250	7.76 [197]	8.07 [205]	1.71 [43,5]	6.06 [154]
MLHS(A,F,B) 315	8.23 [209]	8.50 [216]	2.16 [54,8]	6.50 [165]
MLHS(A,F,B) 400	8.78 [223]	9.05 [230]	2.73 [69,4]	7.05 [179]
MLHS(A,F,B) 475	9.33 [237]	9.61 [244]	3.25 [82,6]	7.60 [193]
MLHS(A,F,B) 525	9.02 [229]	9.29 [236]	2.93 [74,5]	7.28 [185]
MLHS(A,F,B) 565	9.25 [235]	9.53 [242]	3.16 [80,2]	7.52 [191]

* -For Rear Ported Motors.

Standard Rotation
Viewed from Shaft End
Port A Pressurized - **CW**
Port B Pressurized - **CCW**

Reverse Rotation
Viewed from Shaft End
Port A Pressurized - **CCW**
Port B Pressurized - **CW**



DIMENSIONS AND MOUNTING DATA

MLHSW

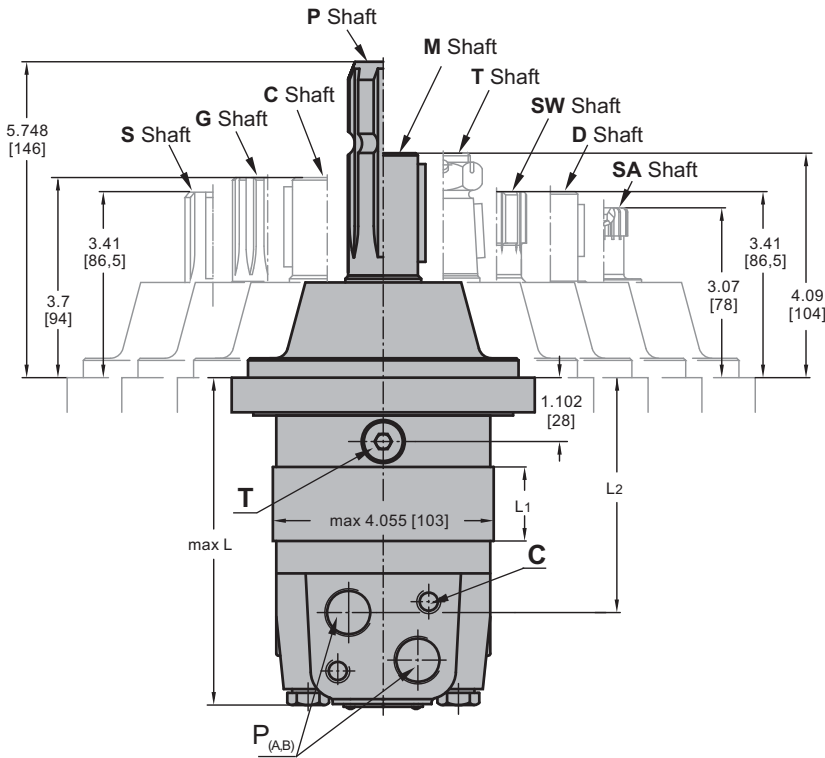

MLHSE

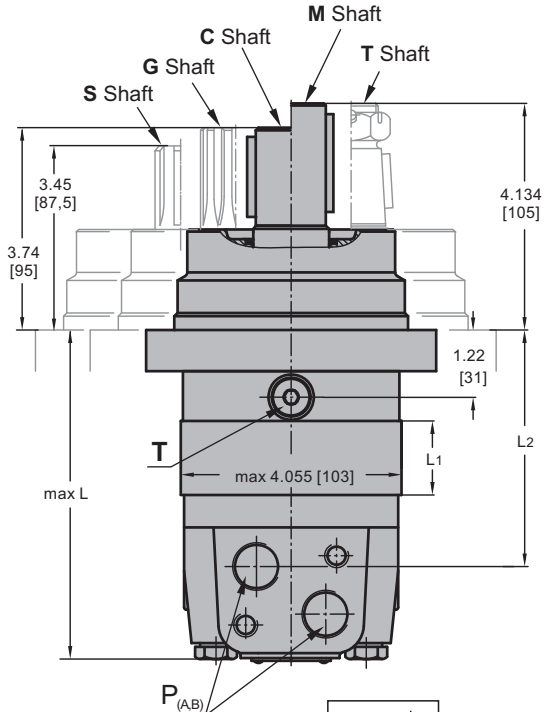

Versions **6 7 8 9**
Rear ports

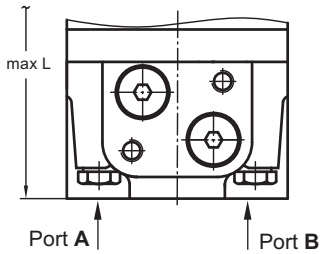

in [mm]

	Versions			
	2,6	3,9	4,7	5,8
C	2xM10	2xM10	2x ³ / ₈ -16UNC	2x ³ / ₈ -16UNC
P_(A,B)	2xG ¹ / ₂	2xM22x1,5	2x ⁷ / ₈ -14UNF	2x ¹ / ₂ -14NPTF
T	G ¹ / ₄	M14x1,5	¹ / ₁₆ -20UNF	¹ / ₁₆ -20UNF

Standard Rotation
Viewed from Shaft End
Port A Pressurized - **CW**
Port B Pressurized - **CCW**

Reverse Rotation
Viewed from Shaft End
Port A Pressurized - **CCW**
Port B Pressurized - **CW**

Type	L max, in [mm]		L2, in [mm]	Type	L max, in [mm]		L2, in [mm]	L1, in [mm]
	Versions 2,3,4,5	*Versions 6,7,8,9			Versions 2,3,4,5	*Versions 6,7,8,9		
MLHSW 80	5.16 [131]	5.43 [138]	3.43 [87]	MLHSE 80	5.24 [133]	5.51 [140]	3.60 [91,5]	.55 [14,0]
MLHSW 100	5.28 [134]	5.59 [142]	3.58 [91]	MLHSE 100	5.39 [137]	5.67 [144]	3.74 [95]	.69 [17,4]
MLHSW 125	5.47 [139]	5.75 [146]	3.74 [95]	MLHSE 125	5.55 [141]	5.83 [148]	3.90 [99]	.86 [21,8]
MLHSW 160	5.71 [145]	5.99 [152]	3.98 [101]	MLHSE 160	5.79 [147]	6.06 [154]	4.13 [105]	1.09 [27,8]
MLHSW 200	5.98 [152]	6.26 [159]	4.25 [108]	MLHSE 200	6.06 [154]	6.34 [161]	4.41 [112]	1.37 [34,8]
MLHSW 250	6.30 [160]	6.62 [168]	4.61 [117]	MLHSE 250	6.42 [163]	6.69 [170]	4.76 [121]	1.71 [43,5]
MLHSW 315	6.73 [171]	7.05 [179]	5.04 [128]	MLHSE 315	6.85 [174]	7.13 [181]	5.20 [132]	2.16 [54,8]
MLHSW 400	7.32 [186]	7.64 [194]	5.63 [143]	MLHSE 400	7.44 [189]	7.72 [196]	5.79 [147]	2.73 [69,4]
MLHSW 475	7.87 [200]	8.15 [207]	6.14 [156]	MLHSE 475	7.95 [202]	8.23 [209]	6.26 [159]	3.25 [82,6]
MLHSW 525	7.56 [192]	7.84 [199]	5.83 [148]	MLHSE 525	7.64 [194]	7.91 [201]	5.95 [151]	2.93 [74,5]
MLHSW 565	7.79 [198]	8.07 [205]	6.06 [154]	MLHSE 565	7.87 [200]	8.15 [207]	6.18 [157]	3.16 [80,2]

* -For Rear Ported Motors.

MOUNTING

SAE A-4 Mount (4 Holes)

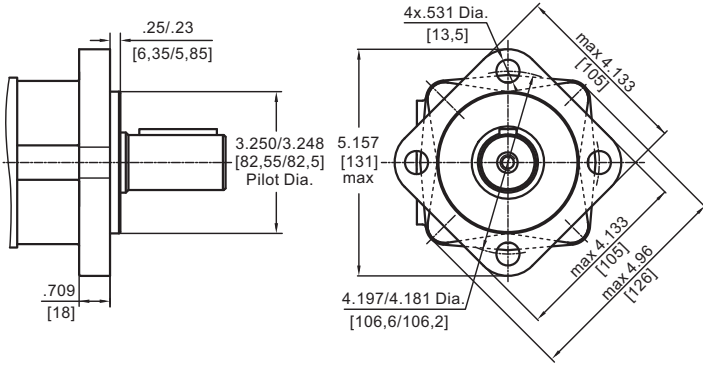

B SAE B Mount (2 Holes)

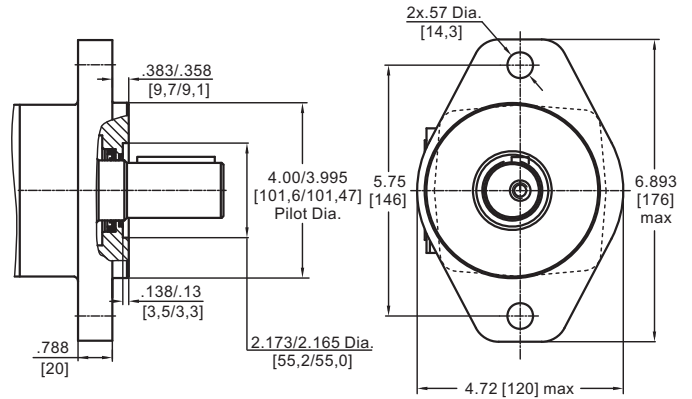

A SAE A-2 Mount (2 Holes)

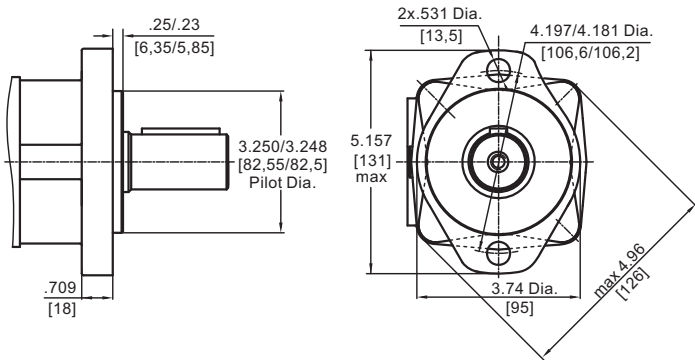

W Wheel Mount

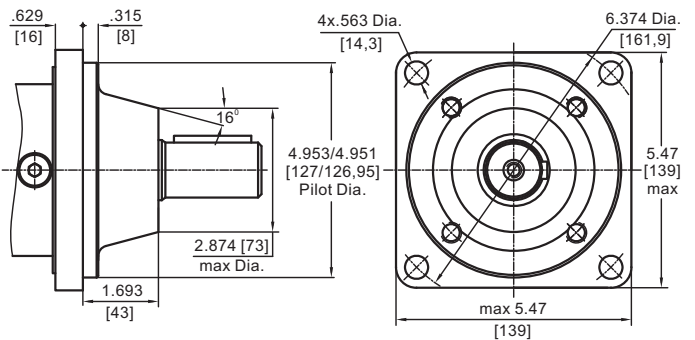

F Magneto Mount (4 Holes)

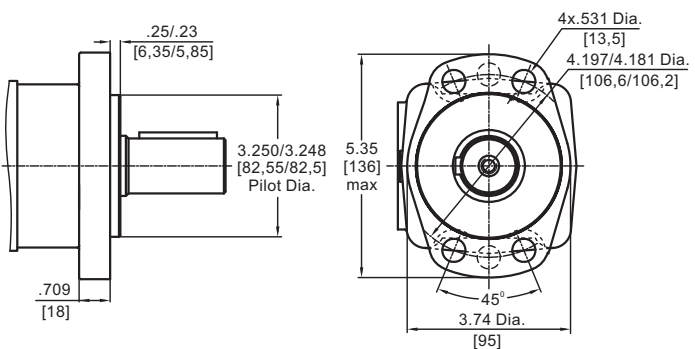

E Wheel Mount

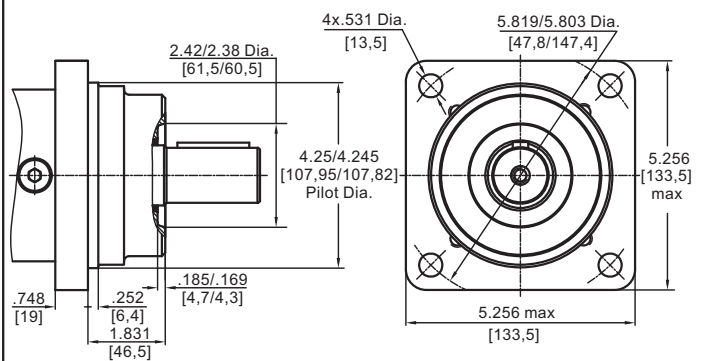

PORTS

Side Ports
Version **2 3 4 5**

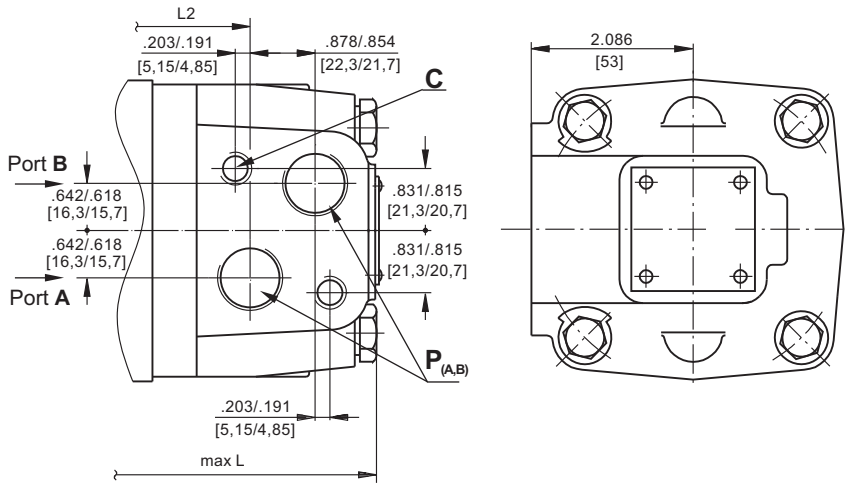

Rear Ports
Version **6 7 8 9**

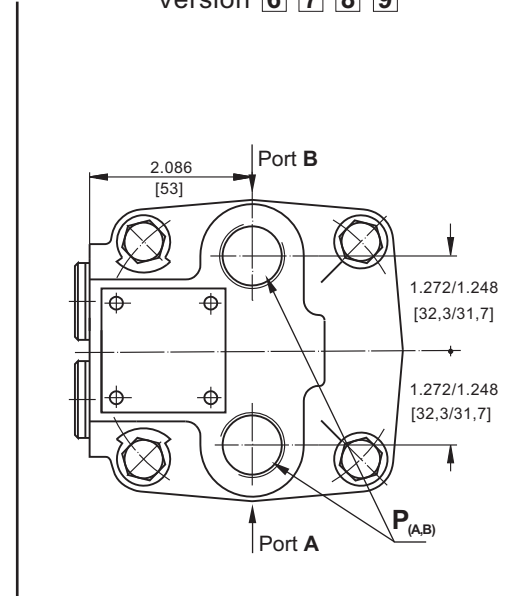

Standard Rotation
Viewed from Shaft End
Port A Pressurized - **CW**
Port B Pressurized - **CCW**

Reverse Rotation
Viewed from Shaft End
Port A Pressurized - **CCW**
Port B Pressurized - **CW**

	Versions			
	2,6	3,9	4,7	5,8
C	2xM10	2xM10	2x $\frac{3}{8}$ -16UNC	2x $\frac{3}{8}$ -16UNC
P(A,B)	2xG $\frac{1}{2}$	2xM22x1,5	2x $\frac{7}{8}$ -14UNF	2x $\frac{1}{2}$ -14NPTF
T	G $\frac{1}{4}$	M14x1,5	$\frac{7}{16}$ -20UNF	$\frac{7}{16}$ -20UNF

MOTORS WITH TACHO CONNECTION

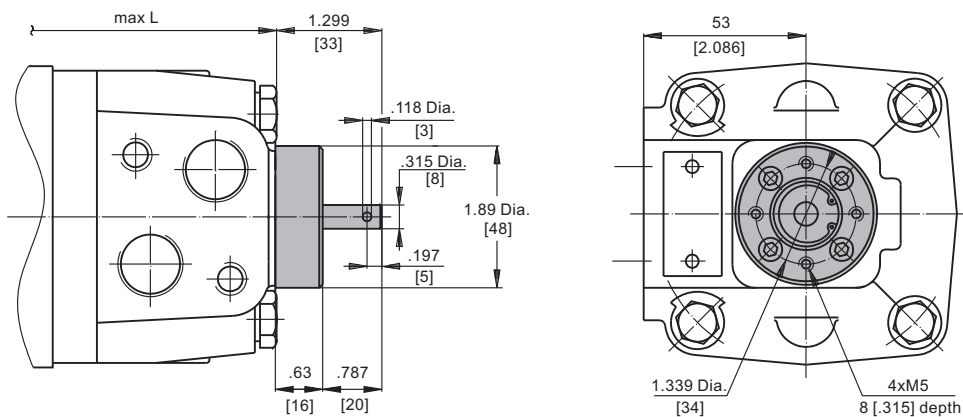

SHAFT EXTENSIONS

C

1 1/4" [31,75] straight, Parallel key 5/16"x 5/16"x 1 1/4" BS46
Max. Torque 6815 in-lb [77 daNm]

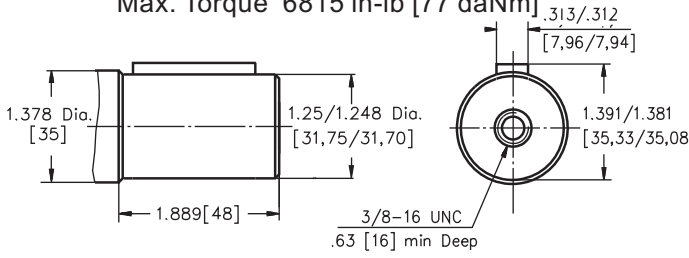

D

1" [25,4] straight, Parallel key 1/4"x 1/4"x 1" BS46
Max. Torque 3900 in-lb [44 daNm]

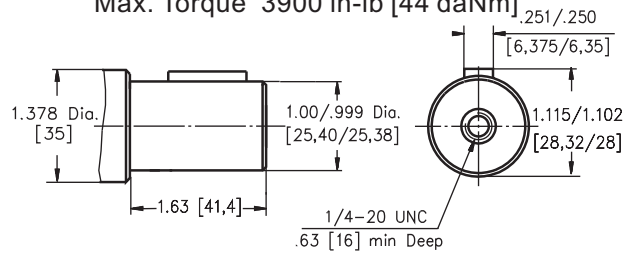

G

14T Splined, 1 1/4" [31,75], ANS B92.1-1976
Max. Torque 6815 in-lb [77 daNm]

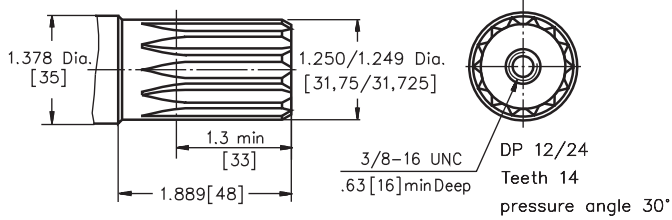

M

ø32 straight, Parallel key A10x8x45 DIN 6885
Max. Torque 6815 in-lb [77 daNm]

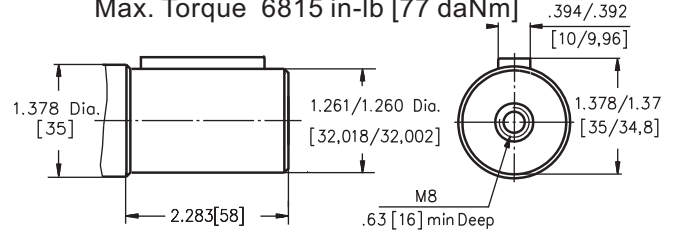

S

1" [25,4], SAE 6B Splined BS2059
Max. Torque 3900 in-lb [44 daNm]

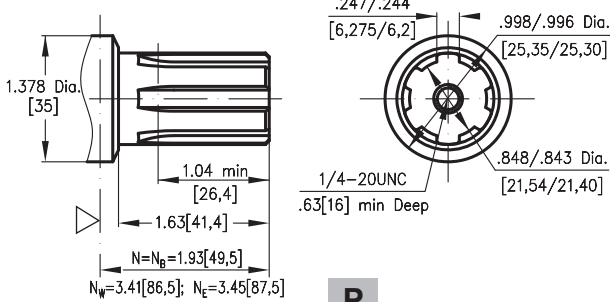

SW

1" [25,4], SAE 6B Splined BS2059
Max. Torque 3400 in-lb [38 daNm]

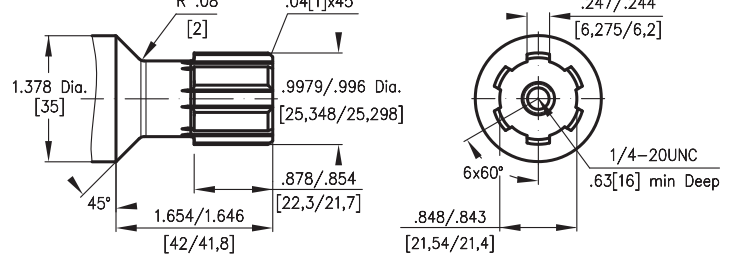

P

ø34,85, p.t.o., DIN 9611 Form 1
Max. Torque 6815 in-lb [77 daNm]

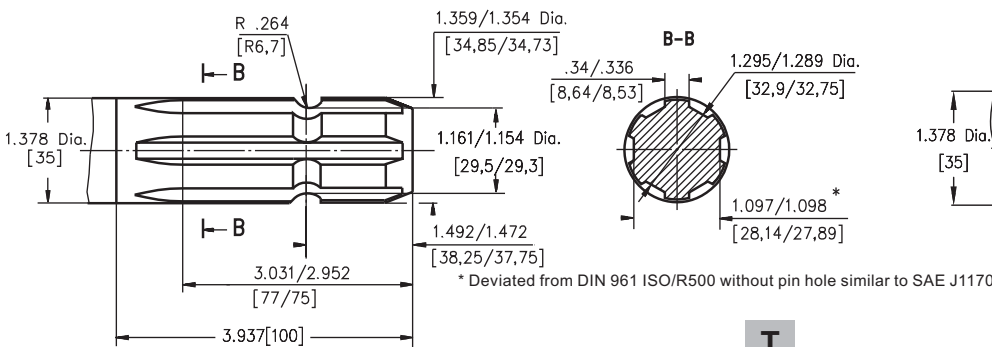

SA

7/8"-13T splined DP16/32 ANS B92.1-1970
Max. Torque 1770 lb-in [20 daNm]

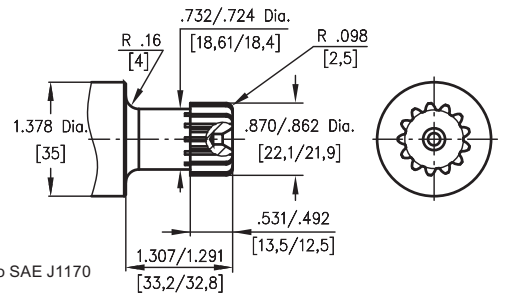

T

1 1/4" [31,75] SAE J501 Tapered, Parallel key 5/16"x 5/16"x 1" BS46
Max. Torque 6815 in-lb [77 daNm]

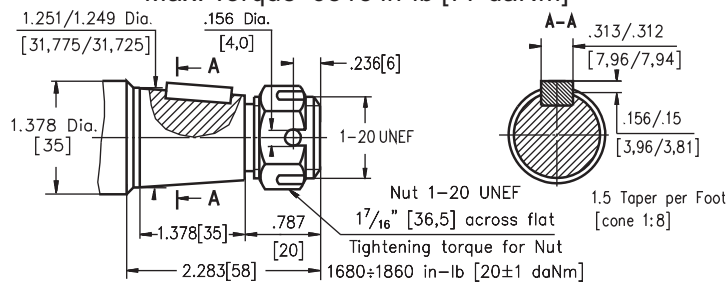

Requirement max. Torque must not be exceeded.



PERMISSIBLE SHAFT LOADS

The output shaft runs in tapered bearings that permit high axial and radial forces. The permissible radial load on the shaft is shown for an axial load of 0 N as function of the distance from the mounting flange to the point of load application. The curves apply to a B10 bearing life of 2000 hours at 100 RPM .

Curve "1" shows max. radial shaft load. Any shaft load exceeding the values shown by the curve will seriously reduce motor life.

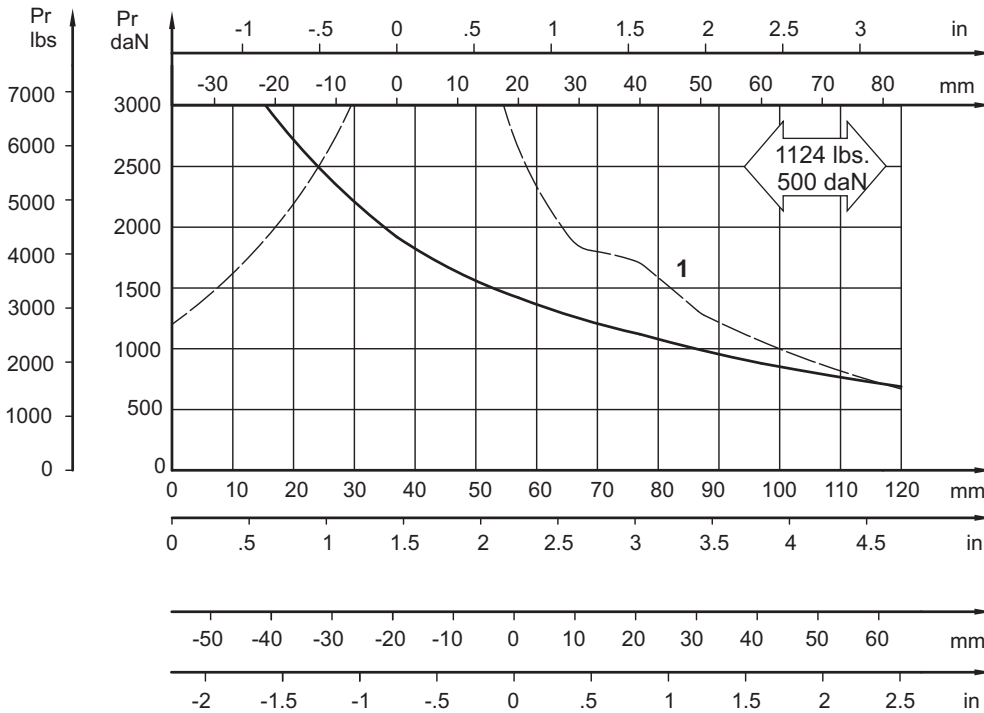

Mounting Flange:

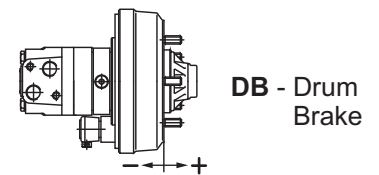
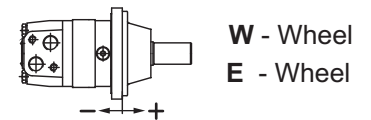
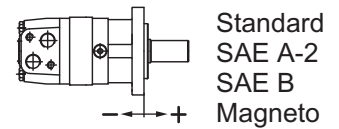

Shaft: All type shafts except SA

FUNCTION DIAGRAM MLHSBD

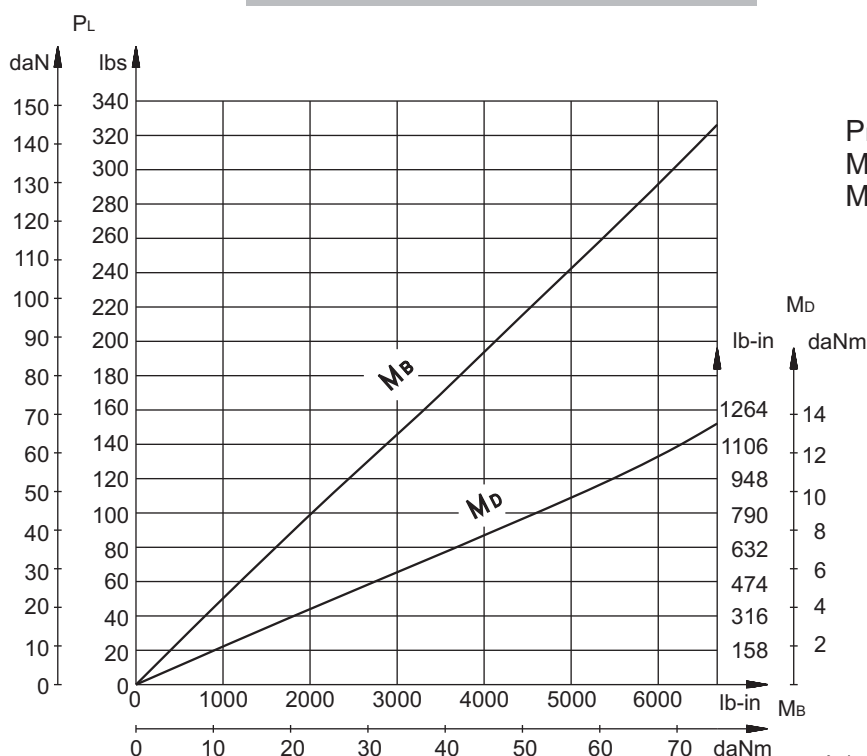

PL - Brake Lever Load
MB - Brake Torque
MD - Brake Lever Torque

DIMENSIONS AND MOUNTING DATA - MLHSS and MLHSZ

S Short Mount

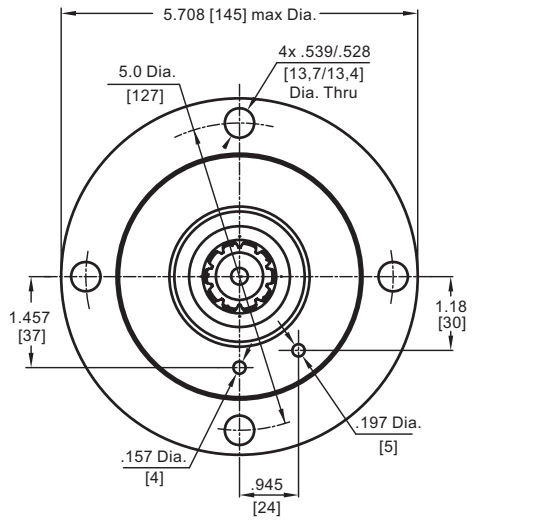

**Z Short Mount
(with place for needle bearing)**

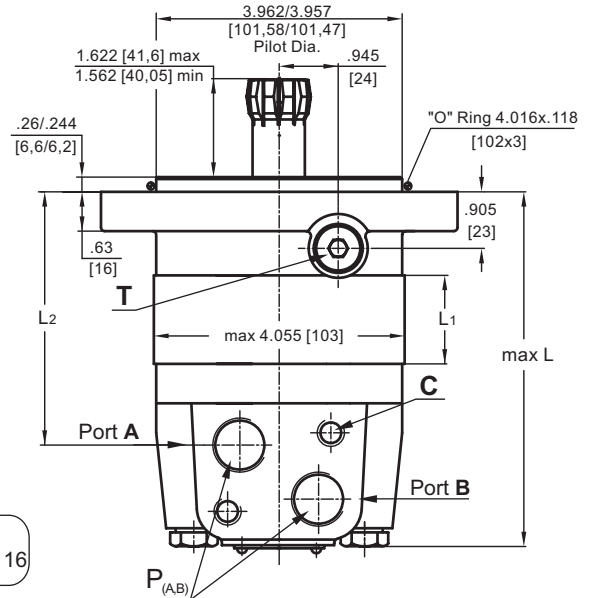
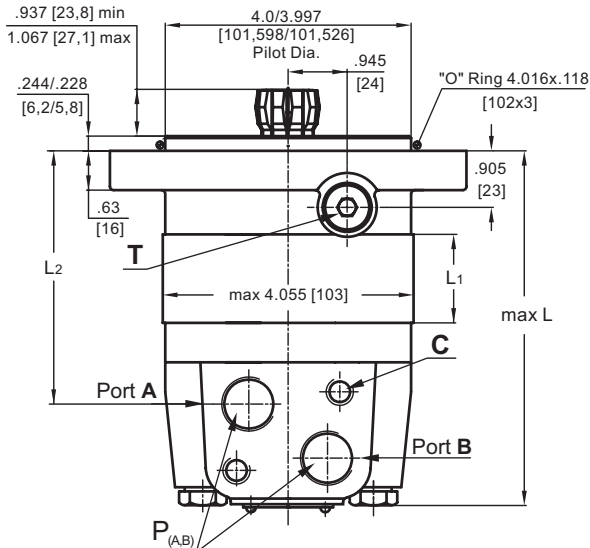
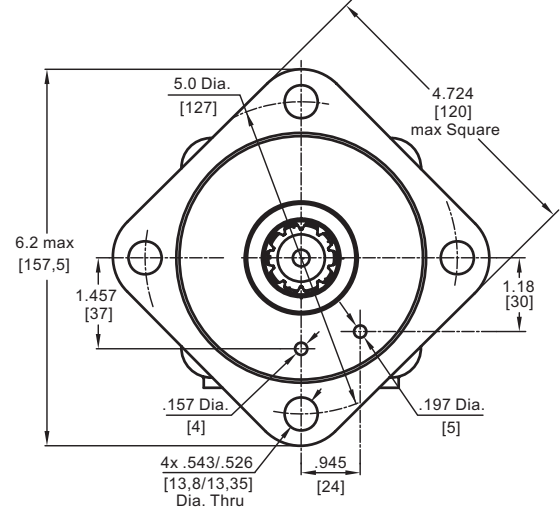

Port Dim.
See Page 16

Versions **6 7 8 9**
Rear ports

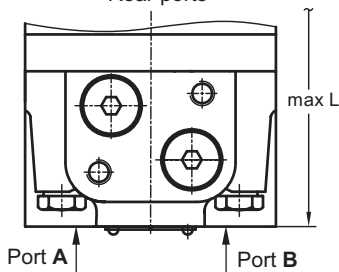

Standard Rotation
Viewed from Shaft End
Port A Pressurized - CW
Port B Pressurized - CCW

Reverse Rotation
Viewed from Shaft End
Port A Pressurized - CCW
Port B Pressurized - CW

		Versions			
		2,6	3,9	4,7	5,8
C	2xM10	2xM10	2x3/8-16UNC	2x3/8-16UNC	
P(A,B)	2xG1/2	2xM22x1,5	2x7/8-14UNF	2x1/2-14NPTF	
T	G1/4	M14x1,5	7/16-20UNF	7/16-20UNF	

Type	L max, in [mm]		L1, in [mm]	L2, in [mm]
	Versions 2,3,4,5	*Versions 6,7,8,9		
MLHSS(Z) 80	4.92 [125]	5.28 [134]	.55 [14,0]	3.27 [83]
MLHSS(Z) 100	5.08 [129]	5.43 [138]	.69 [17,4]	3.43 [87]
MLHSS(Z) 125	5.24 [133]	5.55 [141]	.86 [21,8]	3.54 [90]
MLHSS(Z) 160	5.47 [139]	5.79 [147]	1.09 [27,8]	3.78 [96]
MLHSS(Z) 200	5.75 [146]	6.06 [154]	1.37 [34,8]	4.05 [103]
MLHSS(Z) 250	6.10 [155]	6.42 [163]	1.71 [43,5]	4.41 [112]
MLHSS(Z) 315	6.54 [166]	6.85 [174]	2.16 [54,8]	4.84 [123]
MLHSS(Z) 400	7.13 [181]	7.44 [189]	2.73 [69,4]	5.43 [138]
MLHSS(Z) 475	7.64 [194]	7.99 [203]	3.25 [82,6]	5.98 [152]
MLHSS(Z) 525	7.32 [186]	7.68 [195]	2.93 [74,5]	5.67 [144]
MLHSS(Z) 565	7.56 [192]	7.91 [201]	3.16 [80,2]	5.91 [150]

* -For Rear Ported Motors.

DIMENSIONS AND MOUNTING DATA - MLHSV and MLHSU

V Very Short Mount

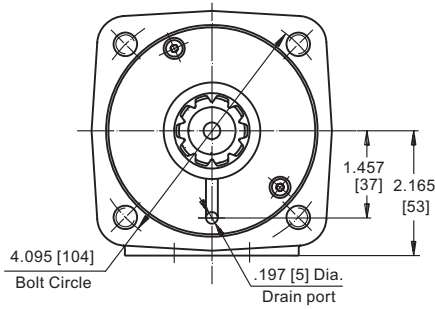

U Ultra Short Mount

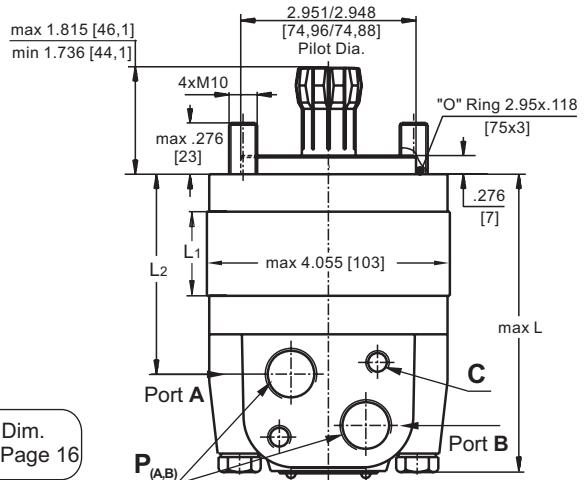
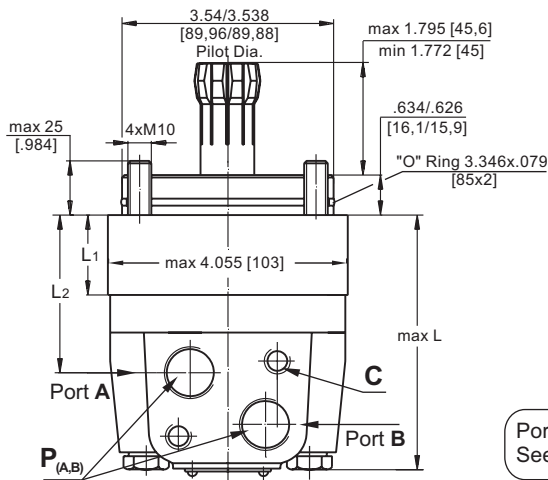
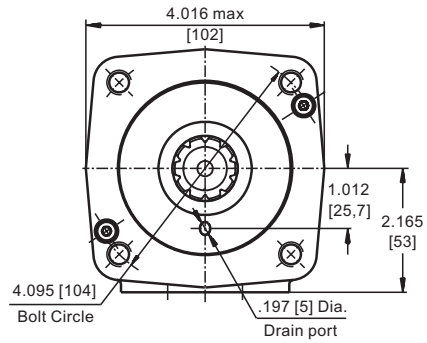

Port Dim.
See Page 16

Versions **6 7 8 9**
Rear ports

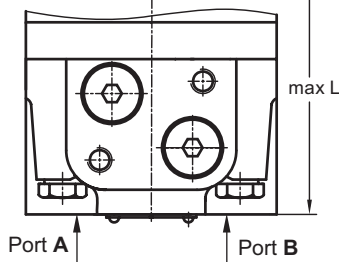

Standard Rotation

Viewed from Shaft End
Port A Pressurized - CW
Port B Pressurized - CCW

Reverse Rotation

Viewed from Shaft End
Port A Pressurized - CCW
Port B Pressurized - CW

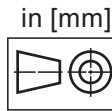

	Versions			
	2,6	3,9	4,7	5,8
C	2xM10	2xM10	2x $\frac{3}{8}$ -16UNC	2x $\frac{3}{8}$ -16UNC
P(A,B)	2xG $\frac{1}{2}$	2xM22x1,5	2x $\frac{7}{8}$ -14UNF	2x $\frac{1}{2}$ -14NPTF

Type	L max, in [mm]		L2, in [mm]	Type	L max, in [mm]		L2, in [mm]	L1, in [mm]
	Versions 2,3,4,5	*Versions 6,7,8,9			Versions 2,3,4,5	*Versions 6,7,8,9		
MLHSV 80	3.58 [91]	3.82 [97]	1.85 [47]	MLHSU 80	4.15 [105,5]	4.39 [111,5]	2.48 [63]	.55 [14,0]
MLHSV 100	3.70 [94]	3.94 [100]	1.99 [50,5]	MLHSU 100	4.29 [109]	4.53 [115]	2.62 [66,5]	.69 [17,4]
MLHSV 125	3.90 [99]	4.13 [105]	2.17 [55]	MLHSU 125	4.45 [113]	4.69 [119]	2.80 [71]	.86 [21,8]
MLHSV 160	4.13 [105]	4.37 [111]	2.40 [61]	MLHSU 160	4.69 [119]	4.92 [125]	3.03 [77]	1.09 [27,8]
MLHSV 200	4.41 [112]	4.64 [118]	2.78 [68]	MLHSU 200	4.96 [126]	5.20 [132]	3.31 [84]	1.37 [34,8]
MLHSV 250	4.72 [120]	4.96 [126]	3.01 [76,5]	MLHSU 250	5.32 [135]	5.55 [141]	3.64 [92,5]	1.71 [43,5]
MLHSV 315	5.20 [132]	5.43 [138]	3.46 [88]	MLHSU 315	5.75 [146]	5.98 [152]	4.09 [104]	2.16 [54,8]
MLHSV 400	5.75 [146]	6.02 [153]	4.05 [103]	MLHSU 400	6.30 [160]	6.58 [167]	4.69 [119]	2.73 [69,4]
MLHSV 475	6.30 [160]	6.54 [166]	4.57 [116]	MLHSU 475	6.85 [174]	7.09 [180]	5.20 [132]	3.25 [82,6]
MLHSV 525	5.98 [152]	6.22 [158]	4.25 [108]	MLHSU 525	6.54 [166]	6.77 [172]	4.88 [124]	2.93 [74,5]
MLHSV 565	6.22 [158]	6.46 [164]	4.49 [114]	MLHSU 565	6.77 [172]	7.01 [178]	5.12 [130]	3.16 [80,2]

* -For Rear Ported Motors.

DIMENSIONS OF THE ATTACHED COMPONENT

For MLHSS

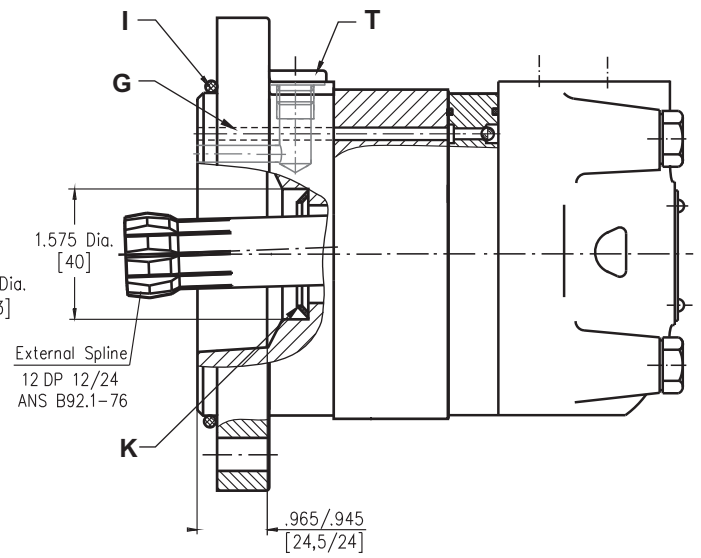
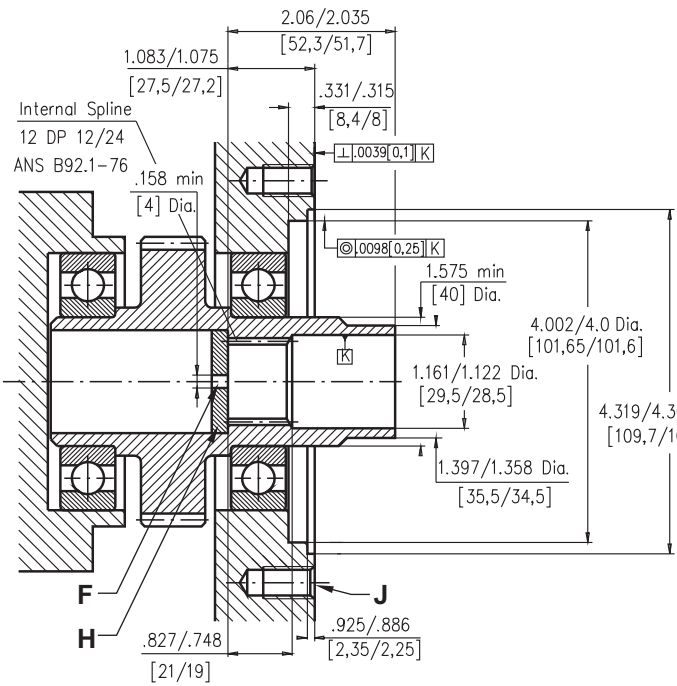

For MLHSZ

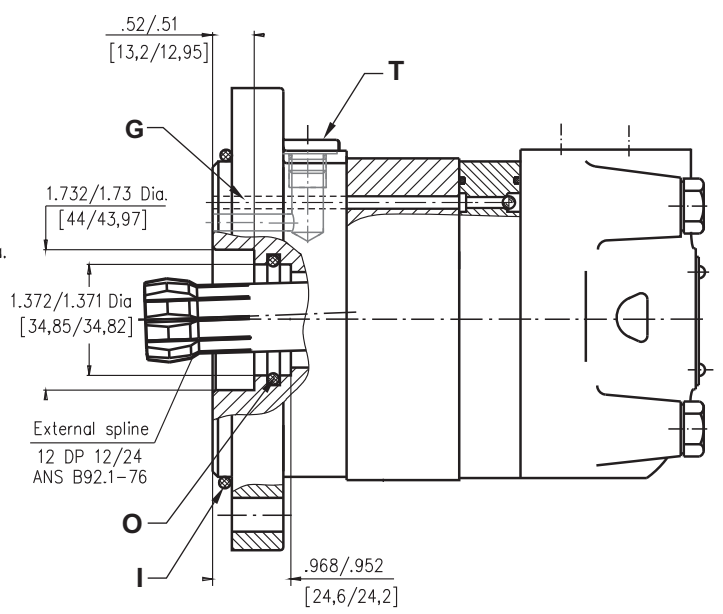
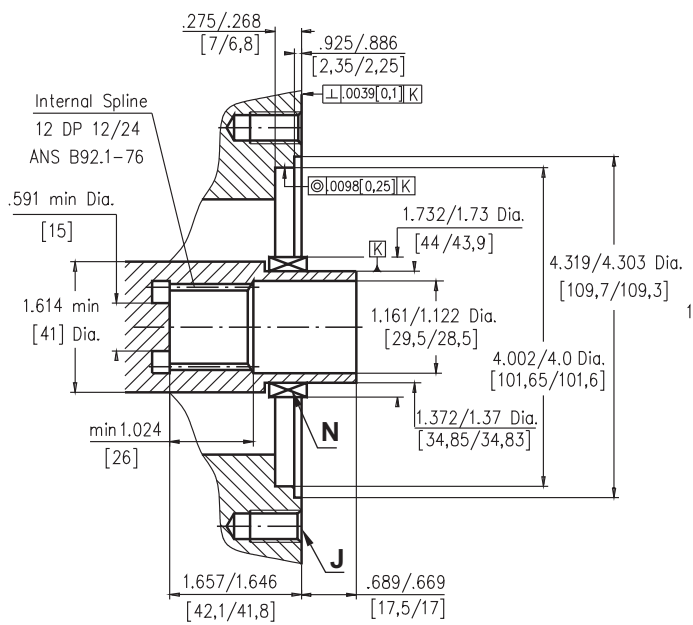

- F:** Oil circulation hole
- H:** Hardened stop plate
- I:** "O"- Ring 4.016x .118 [102x3]
- K:** Conical seal ring

- G:** Internal drain channel
- J:** 4x½ UN- min .61 [15] Deep, 90°, 5.00[127] Dia. B.C.
- N:** Needle bearing 1⅜"x 1¼"
- O:** "O"- Ring 1.358x .104 [34,5x2,65]
- T:** Drain connection G1/4, M14x1,5 or ⅞-20UNF

DIMENSIONS OF THE ATTACHED COMPONENT (continued)

For MLHSV

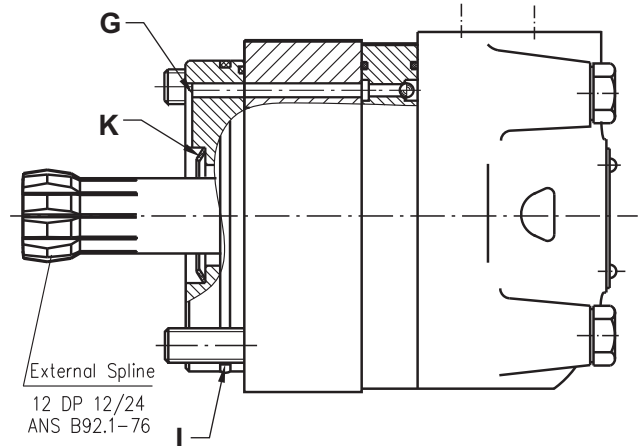
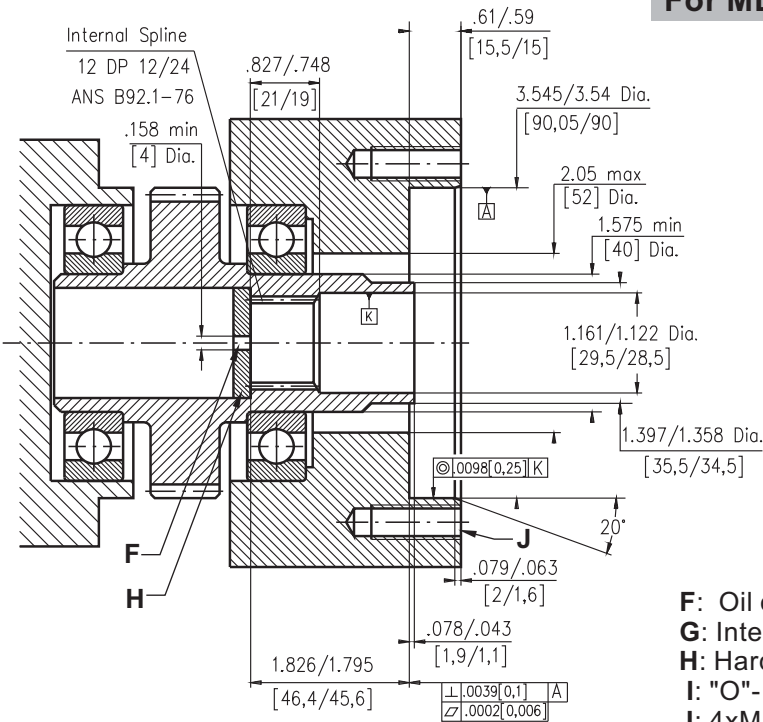

- F:** Oil circulation hole
- G:** Internal drain channel
- H:** Hardened stop plate
- I:** "O"- Ring 3.346x .079 [85x2]
- J:** 4xM10- min 1.024 [26] Deep, 90°, 4.095[104] Dia. B.C.
- K:** Conical seal ring

For MLHSU

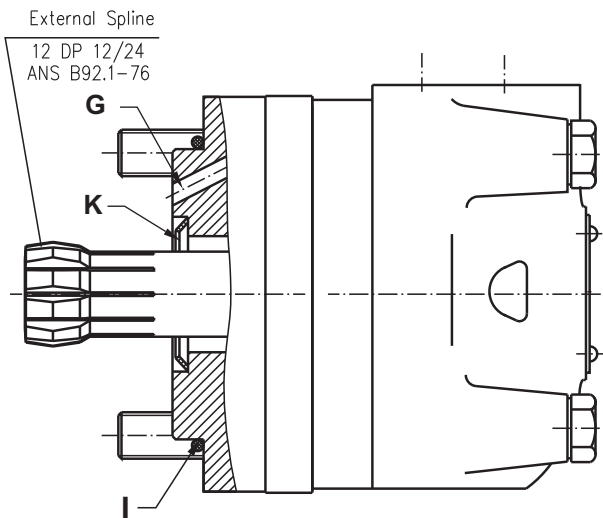
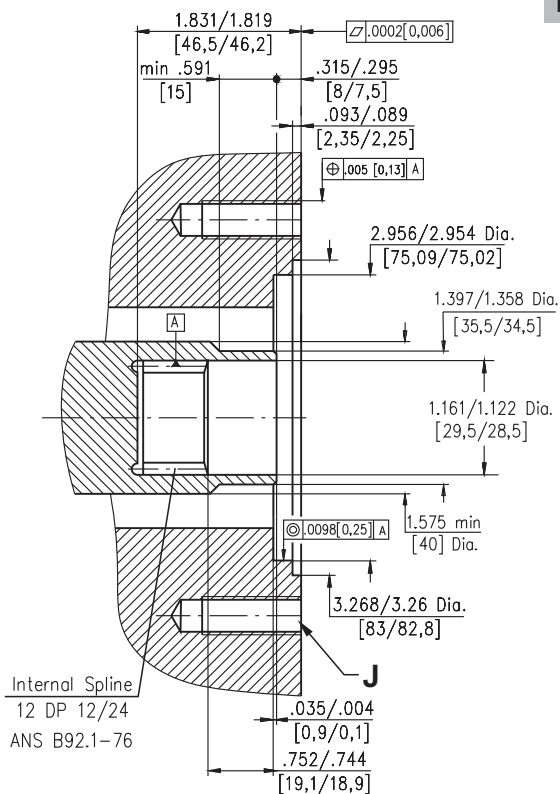

- I:** "O"- Ring 2.95x .118 [75x3]
- J:** 4xM10- min 1.024 [26] Deep, 90°, 4.095[104] Dia. B.C.
- G:** Internal drain channel
- K:** Conical seal ring

DRAIN CONNECTION

A drain line has to be used when pressure in the return line can exceed the permissible pressure. It can be connected:

- For MLHSS, MLHSZ at the drain port of the motor;
- For MLHSV, MLHSU at the drain connection of the attached component. The maximum pressure in the drain line is limited by the attached component and its shaft seal.

The drain line must be possible for oil to flow freely between motor and attached component and must be led to the tank. The maximum pressure in the drain line is limited by the attached component and its seal.

INTERNAL SPLINE DATA FOR THE ATTACHED COMPONENT

Standard ANS B92.1-1976, class 5
[$m=2.1166$; corrected $x.m=0.8$]

Fillet Root Side Fit	inch	mm
Number of Teeth	z	12
Diametral Pitch	DP	12/24
Pressure Angle		30°
Pitch Dia.	D	1
Major Dia.	D _{ri}	1.1 ± 1.098
Minor Dia.	D _i	.907 ± .905
Space Width [Circular]	L _o	.1704 ± .1688
Fillet Radius	R	.008
Max. Measurement between Pins	L	.699 ± .694
Pin Dia.	d	.19039 ± .19031

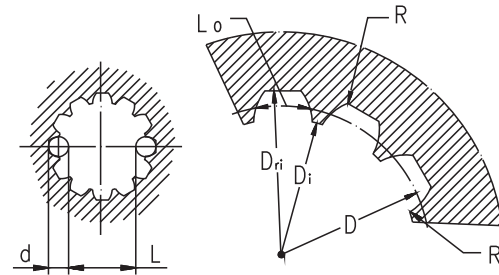

Hardening Specification:
HV=750±50 on the surface.
HV=560 at .035±.019 [0,7±0,2] case depth.
Material: 20 MoCr4 DIN 17210 or SAE8620.

ORDER CODE

	1	2	3	4	5	6	7	8
MLHS								

Pos.1 - Mounting Flange

- omit - SAE A-4, four holes
- A** - SAE A-2, two holes
- B** - SAE B, two holes
- E** - Wheel mount, 4.25 Pilot Dia.**
- F** - Magneto, four holes (six holes at customer's request)
- S** - Short
- V** - Very short
- U** - Ultra short
- W** - Wheel mount, 5.00 Pilot Dia.
- Z** - Short, with place for needle bearing
- BD** - With drum brake

Pos.2 - Displacement code

- 80** - 4.91 [80,5] in³/rev [cm³/rev]
- 100** - 6.10 [100,0] in³/rev [cm³/rev]
- 125** - 7.67 [125,7] in³/rev [cm³/rev]
- 160** - 9.74 [159,7] in³/rev [cm³/rev]
- 200** - 12.20 [200,0] in³/rev [cm³/rev]
- 250** - 15.30 [250,0] in³/rev [cm³/rev]
- 315** - 19.20 [314,9] in³/rev [cm³/rev]
- 400** - 24.20 [397,0] in³/rev [cm³/rev]
- 475** - 28.96 [474,6] in³/rev [cm³/rev]
- 525** - 31.88 [522,7] in³/rev [cm³/rev]
- 565** - 34.47 [564,9] in³/rev [cm³/rev]

Notes : * The permissible output torque for shafts must not be exceeded!

** The motor MLHSE is not available with shafts D, P, S, SA.

The hydraulic motors are mangano-phosphatized as standard.

Pos. 3 - Shaft Extensions*

- omit - for **BD, S, Z, V** and **U** mounting flange
- C** - 1¼" [31,75] straight, Parallel key
- D** - 1" [25,4] straight, Parallel key
- G** - 1¼" [31,75] 14T Splined
- M** - 32 mm straight, Parallel key
- P** - 34,85 mm Splined, p.t.o. DIN 9611 Form 1
- S** - 1" [25,4] SAE 6B Splined
[Max. Torque 3900 in-lb [44 daNm]
- SW** - 1" [25,4] SAE 6B Splined
[Max. Torque 3400 in-lb [38 daNm]
- SA** - 7/8"-13T splined ANS B92.1-1970
- T** - 1¼" [31,75] J501 Tapered

Pos. 4 - Actuating Direction [for MLHSBD only]

- /R** - right
- /L** - left

Pos. 5 - Port Size/Type [standard manifold to each]

- 2** - side ports, 2xG1/2, G1/4, BSP thread, ISO 228
- 3** - side ports, 2xM22x1,5; M14x1,5; metric thread, ISO 262
- 4** - side ports, 2x7/8-14 UNF, O-ring, 7/16-20 UNF
- 5** - side ports, 2x1/2-14 NPTF, 7/16-20 UNF
- 6** - rear ports, 2xG1/2; G1/4; BSP thread, ISO 228
- 7** - rear ports, 2x7/8-14 UNF, O-ring, 7/16-20 UNF
- 8** - rear ports, 2x1/2-14 NPTF, 7/16-20 UNF
- 9** - rear ports, 2xM22x1,5, M14x1,5; metric thread, ISO 262

Pos. 6 - Special Features [see page 51]

Pos. 7 - Design Series

- omit - Factory specified

HYDRAULIC MOTORS MLHT



APPLICATION

- » Conveyors
- » Metal working machines
- » Agricultural machines
- » Road building machines
- » Mining machinery
- » Food industries
- » Special vehicles etc.

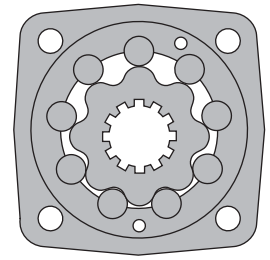
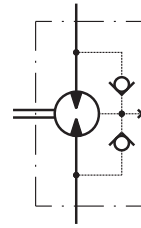

CONTENTS

Specification data	26+27
Performance data	28+31
Dimensions and mounting	32+33
Shaft extensions	34
Permissible shaft seal pressure	34
Dimensions and mounting- MLHTS, V	35
Dimensions of the attached component	36
Internal Spline data	37
Permissible shaft loads	37
Tacho connection.....	38
Order code	38

OPTIONS

- » Model - Disc valve, roll-gerotor
- » Flange and wheel mount
- » Short motor
- » Tacho connection
- » Speed sensing
- » Side and rear ports
- » Shafts- straight, splined and tapered
- » SAE, Metric and BSPP ports
- » Other special features

GENERAL

Max. Displacement, in ³ /rev [cm ³ /rev]	44.2 [724,3]
Max. Speed, [RPM]	775
Max. Torque, lb-in [daNm]	cont.: 11500 [130] int.: 13100 [148]
Max. Output, HP [kW]	54 [40]
Max. Pressure Drop, PSI [bar]	cont.: 2900 [200] int. 3480 [240]
Max. Oil Flow, GPM [lpm]	150 [39.6]
Min. Speed, [RPM]	5
Permissible Shaft Loads lbs [daN]	P _a =2250 [1000]
Pressure fluid	Mineral based- HLP(DIN 51524) or HM(ISO 6743/4)
Temperature range, °F [°C]	-40÷140 [-40÷284]
Optimal Viscosity range, SUS [mm²/s]	20 ÷ 75 [98 ÷ 347]
Filtration	ISO code 20/16 (Min. recommended fluid filtration of 25 microns)

Oil flow in drain line

Pressure drop PSI [bar]	Viscosity SUS [mm ² /s]	Oil flow in drain line GPM [lpm]
2030 [140]	98 [20]	.660 [2,5]
	164 [35]	.396 [1,5]
3045 [210]	98 [20]	1.321 [5]
	164 [35]	.793 [3]

Pressure Losses

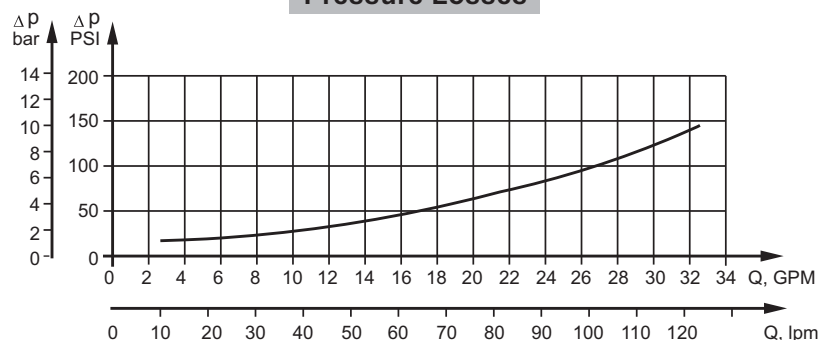

SPECIFICATION DATA

Type	MLHT 160	MLHT 200	MLHT 250	MLHT 315
Displacement, in³/rev [cm³/rev]	9.83 [161,1]	12.29 [201,4]	15.36 [251,8]	19.90 [326,3]
Max. Speed, [RPM]	Cont.	622	620	496
	Int.*	775	752	601
Max. Torque lb-in [daNm]	Cont.	4160 [47]	5220 [59]	6460 [73]
	Int.*	4960 [56]	6285 [71]	7790 [88]
	Peak**	5840 [66]	7260 [82]	9030 [102]
Max. Output HP [kW]	Cont.	36 [26,5]	45 [33,5]	45 [33,5]
	Int.*	43 [32]	54 [40]	54 [40]
Max. Pressure Drop PSI [bar]	Cont.	2900 [200]	2900 [200]	2900 [200]
	Int.*	3450 [240]	3450 [240]	3450 [240]
	Peak**	4050 [280]	4050 [280]	4050 [280]
Max. Oil Flow GPM [lpm]	Cont.	26,4 [100]	33 [125]	33 [125]
	Int.*	33 [125]	39.6 [150]	39.6 [150]
Max. Inlet Pressure PSI [bar]	Cont.	3050 [210]	3050 [210]	3050 [210]
	Int.*	3600 [250]	3600 [250]	3600 [250]
	Peak**	4350 [300]	4350 [300]	4350 [300]
Max. Return Pressure with Drain Line PSI [bar]	Cont.	2030 [140]	2030 [140]	2030 [140]
	Int.*	2540 [175]	2540 [175]	2540 [175]
	Peak**	3050 [210]	3050 [210]	3050 [210]
Max. Starting Pressure with Unloaded Shaft, PSI [bar]	150 [10]	150 [10]	150 [10]	150 [10]
Min. Starting Torque lb-in [daNm]	At max. press. drop Cont.	3010 [34]	3800 [43]	4690 [53]
	At max. press. drop Int.*	3630 [41]	4600 [52]	5580 [63]
Min. Speed***, [RPM]	10	9	8	7
Weight, lb [kg] For Rear Ports +0,450[.992]	MLHT	44.1 [20]	47.4 [21,5]	46.3[21]
	MLHTW	48.5 [22]	49.6 [22,5]	50.7 [23]
	MLHTS	33.1 [15]	34.2 [15,5]	35.3 [16]
	MLHTV	24.3 [11]	25.4 [11,5]	26.5 [12]

* Intermittent operation: the permissible values may occur for max. 10% of every minute.

** Peak load: the permissible values may occur for max. 1% of every minute.

*** For speeds lower than given, consult factory or your regional manager.

1. Intermittent speed and intermittent pressure drop must not occur simultaneously.
2. Recommended filtration is per ISO cleanliness code 20/16. A nominal filtration of 25 micron or better.
3. Recommend using a premium quality, anti-wear type mineral based hydraulic oil HLP(DIN51524) or HM (ISO 6743/4).
If using synthetic fluids consult the factory for alternative seal materials.
4. Recommended minimum oil viscosity 70 SUS [13 mm²/s] at 122°F [50°C].
5. Recommended maximum system operating temperature is 180°F [82°C].
6. To assure optimum motor life fill with fluid prior to loading and run at moderate load and speed for 10-15 minutes.

SPECIFICATION DATA (continued)

Type		MLHT 400	MLHT 500	MLHT 630	MLHT 725
Displacement, in³/rev [cm³/rev]		25.06 [410,9]	31.95 [523,6]	38.52 [631,2]	44.2 [724,3]
Max. Speed, [RPM]	Cont.	304	238	197	172
	Int.*	368	289	234	209
Max. Torque lb-in [daNm]	Cont.	9560 [108]	10800 [122]	11500 [130]	11240 [127]
	Int.*	11150 [126]	12125 [137]	13100 [148]	13010 [147]
	Peak**	12745 [144]	14160 [160]	15580 [176]	15490 [175]
Max. Output HP [kW]	Cont.	40 [30]	36 [26,5]	33 [24,3]	27 [20,2]
	Int.*	47 [35]	40 [30]	37 [27,5]	36 [26,8]
Max. Pressure Drop PSI [bar]	Cont.	2600 [180]	2300 [160]	2010 [140]	1740 [120]
	Int.*	3050 [210]	2600 [180]	2310 [160]	2010 [140]
	Peak**	3450 [240]	3050 [210]	2760 [190]	2395 [165]
Max. Oil Flow GPM [lpm]	Cont.	33 [125]	33 [125]	33 [125]	33 [125]
	Int.*	39.6 [150]	39.6 [150]	39.6 [150]	39.6 [150]
Max. Inlet Pressure PSI [bar]	Cont.	3050 [210]	3050 [210]	3050 [210]	3050 [210]
	Int.*	3600 [250]	3600 [250]	3600 [250]	3600 [250]
	Peak**	4350 [300]	4350 [300]	4350 [300]	4350 [300]
Max. Return Pressure with Drain Line PSI [bar]	Cont.	2000 [140]	2000 [140]	2000 [140]	2000 [140]
	Int.*	2500 [175]	2500 [175]	2500 [175]	2500 [175]
	Peak**	3000 [210]	3000 [210]	3000 [210]	3000 [210]
Max. Starting Pressure with Unloaded Shaft, PSI [bar]		150 [10]	150 [10]	150 [10]	150 [10]
Min. Starting Torque lb-in [daNm]	At max. press. drop Cont.	7435 [84]	8410 [95]	8410 [95]	8410 [95]
	At max. press. drop Int.*	8585 [97]	9380 [106]	9740 [110]	10180 [115]
Min. Speed***, [RPM]		6	5	5	5
Weight, lb [kg] For Rear Ports +0,450 [.992]	MLHT	50.7 [23]	52.9 [24]	51.8 [23,5]	54.0 [24,5]
	MLHTW	55.1 [25]	57.3 [26]	56.2 [25,5]	58.4 [26,5]
	MLHTS	39.7 [18]	41.9 [19]	40.8 [18,5]	43.0 [19,5]
	MLHTV	30.9 [14]	33.1 [15]	32.0 [14,5]	34.2 [15,5]

* Intermittent operation: the permissible values may occur for max. 10% of every minute.

** Peak load: the permissible values may occur for max. 1% of every minute.

*** For speeds lower than given, consult factory or your regional manager.

1. Intermittent speed and intermittent pressure drop must not occur simultaneously.
2. Recommended filtration is per ISO cleanliness code 20/16. A nominal filtration of 25 micron or better.
3. Recommend using a premium quality, anti-wear type mineral based hydraulic oil HLP(DIN51524) or HM (ISO 6743/4).
If using synthetic fluids consult the factory for alternative seal materials.
4. Recommended minimum oil viscosity 70 SUS [13 mm²/s] at 122°F [50°C].
5. Recommended maximum system operating temperature is 180°F [82°C].
6. To assure optimum motor life fill with fluid prior to loading and run at moderate load and speed for 10-15 minutes.

FUNCTION DIAGRAMS

MLHT 160

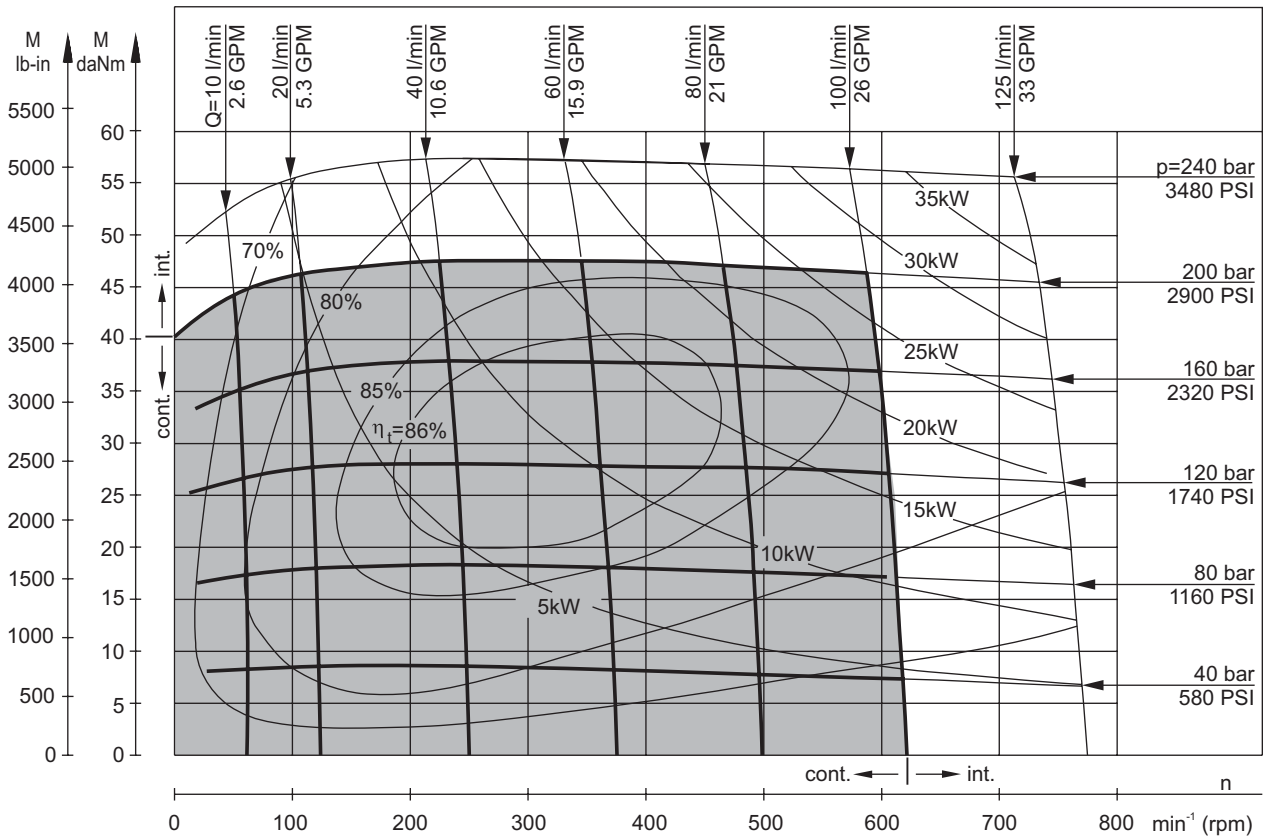

MLHT 200

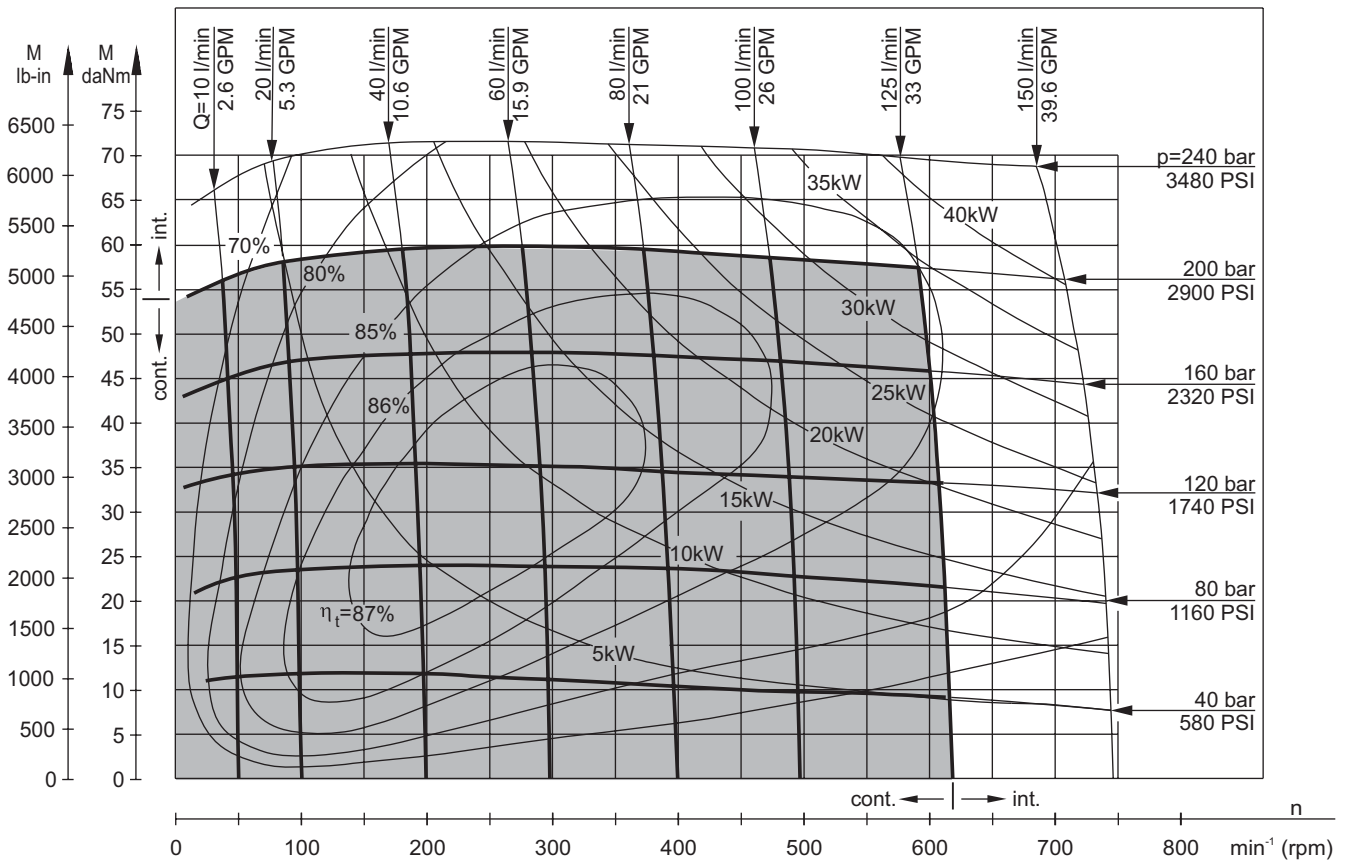

The function diagrams data is for average performance of randomly selected motors at back pressure 5 ± 10 bar [72.5 \pm 145 PSI] and oil with viscosity of 32 mm²/s [150 SUS] at 50°C [122°F].

FUNCTION DIAGRAMS

MLHT 250

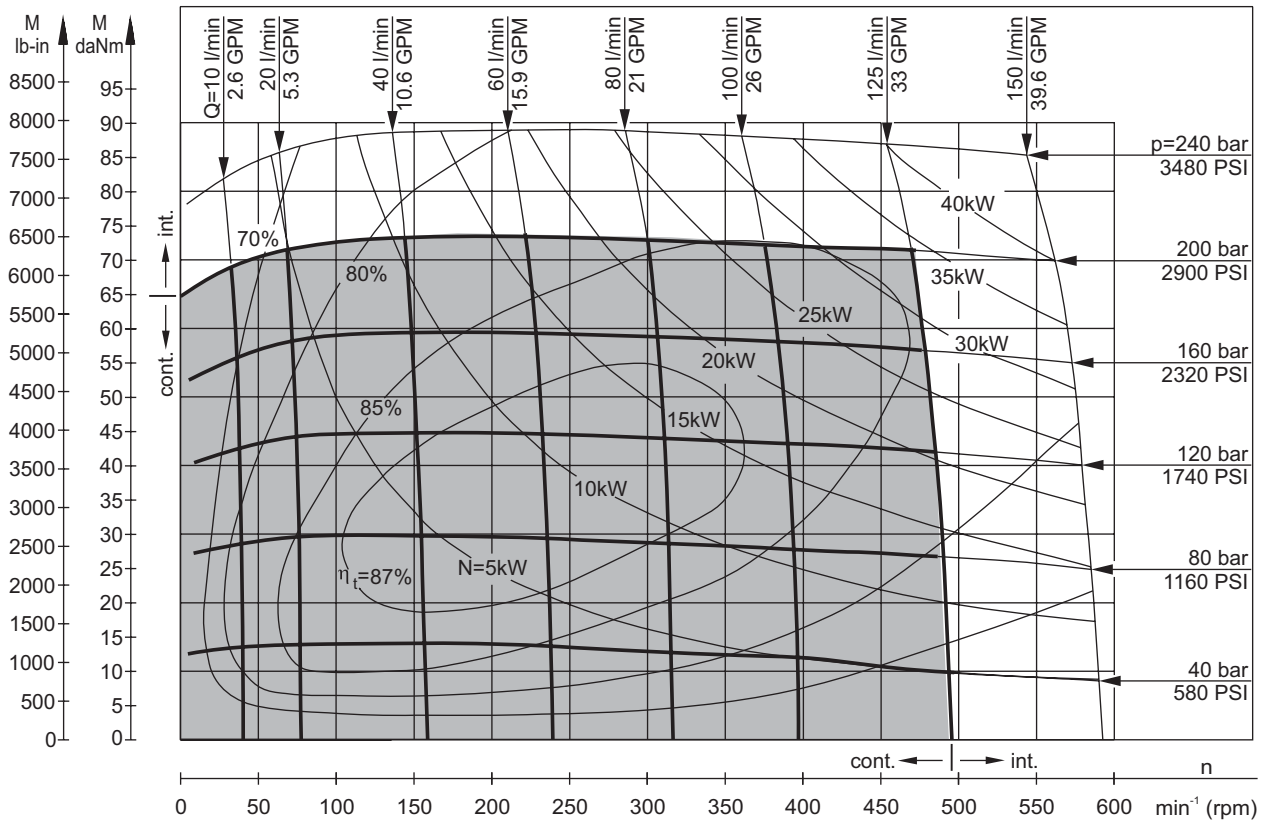

MLHT 315

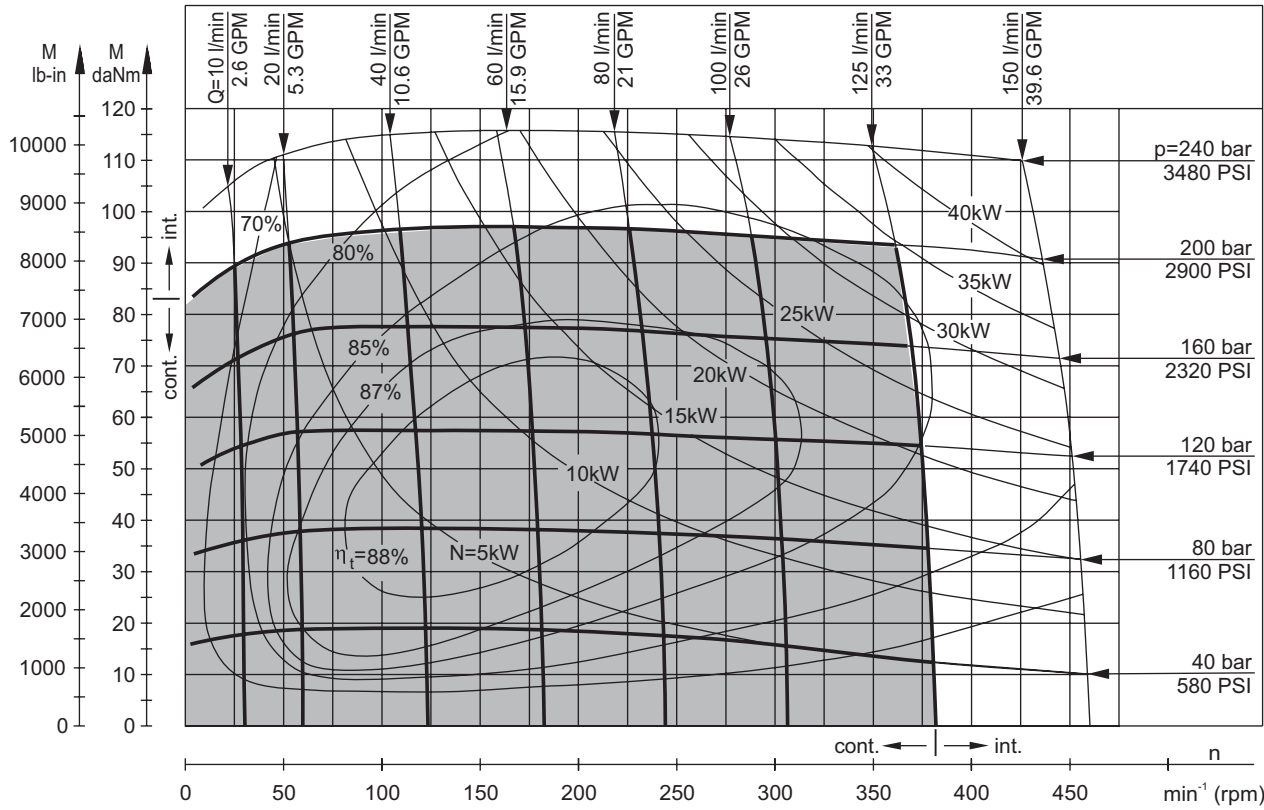

The function diagrams data is for average performance of randomly selected motors at back pressure 5 ± 10 bar [72.5 ± 145 PSI] and oil with viscosity of 32 mm²/s [150 SUS] at 50°C [122°F].

FUNCTION DIAGRAMS

MLHT 400

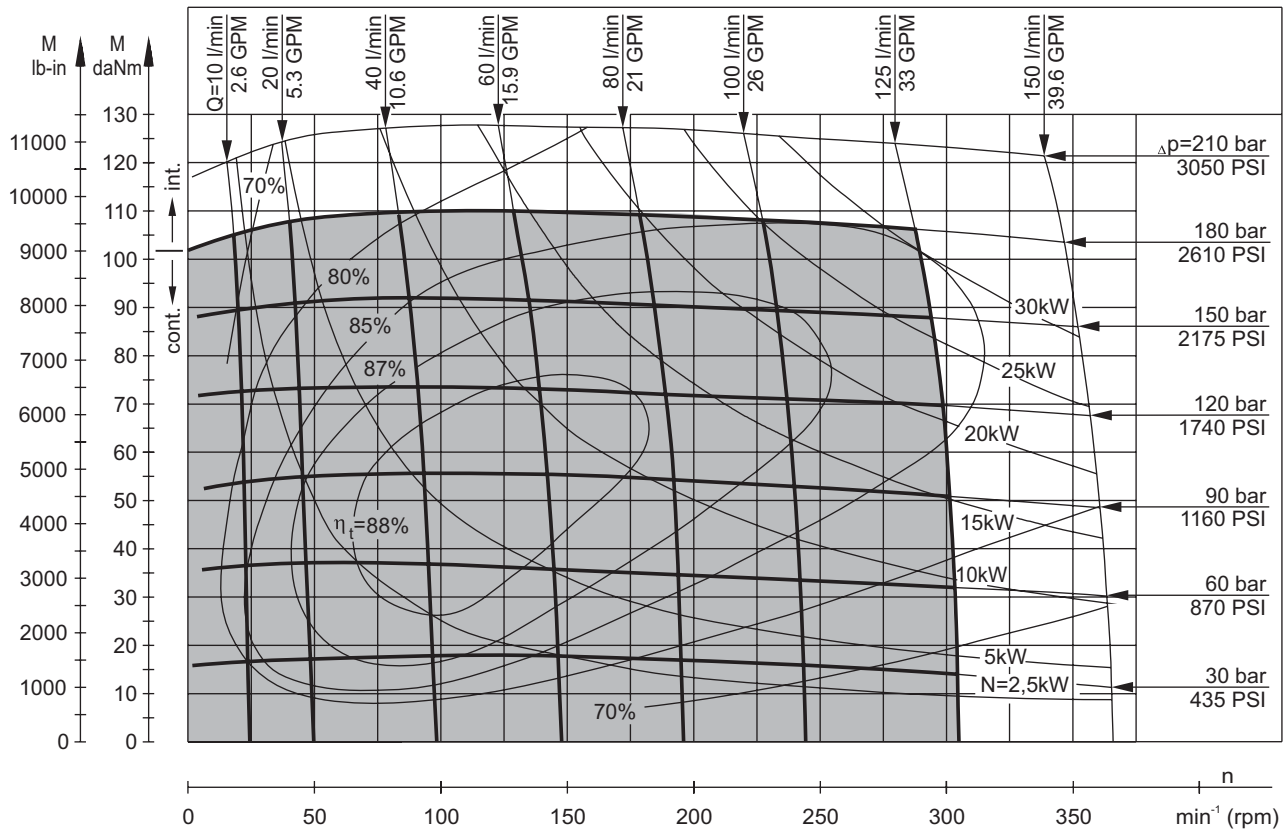

MLHT 500

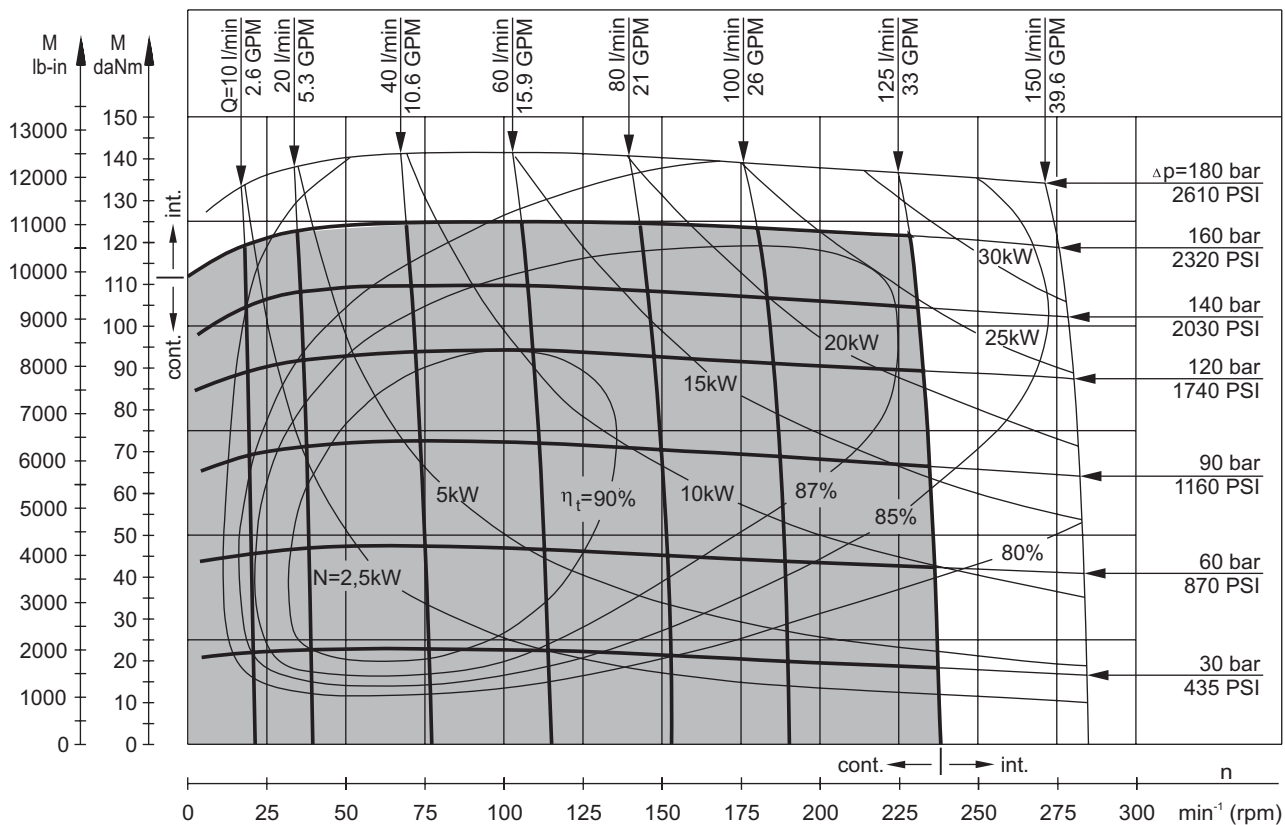

The function diagrams data is for average performance of randomly selected motors at back pressure 5 ± 10 bar [72.5±145 PSI] and oil with viscosity of 32 mm²/s [150 SUS] at 50°C [122°F].

FUNCTION DIAGRAMS

MLHT 630

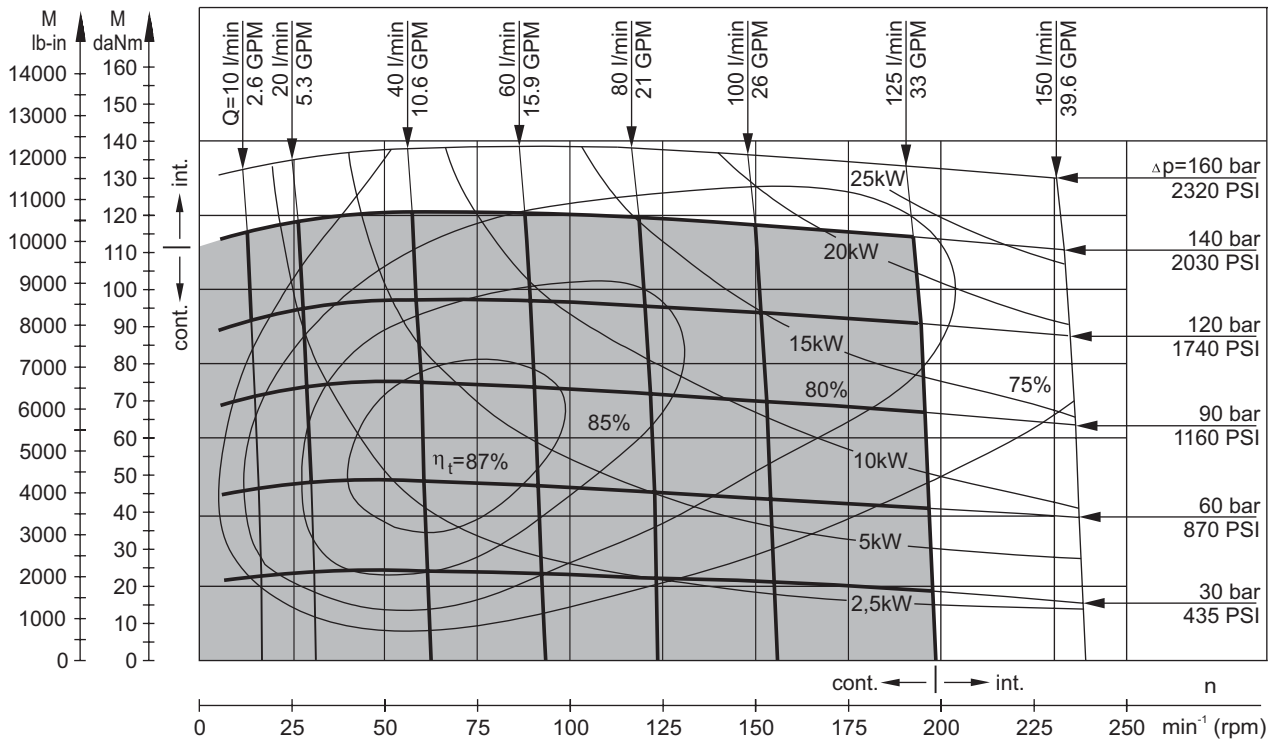

MLHT 725

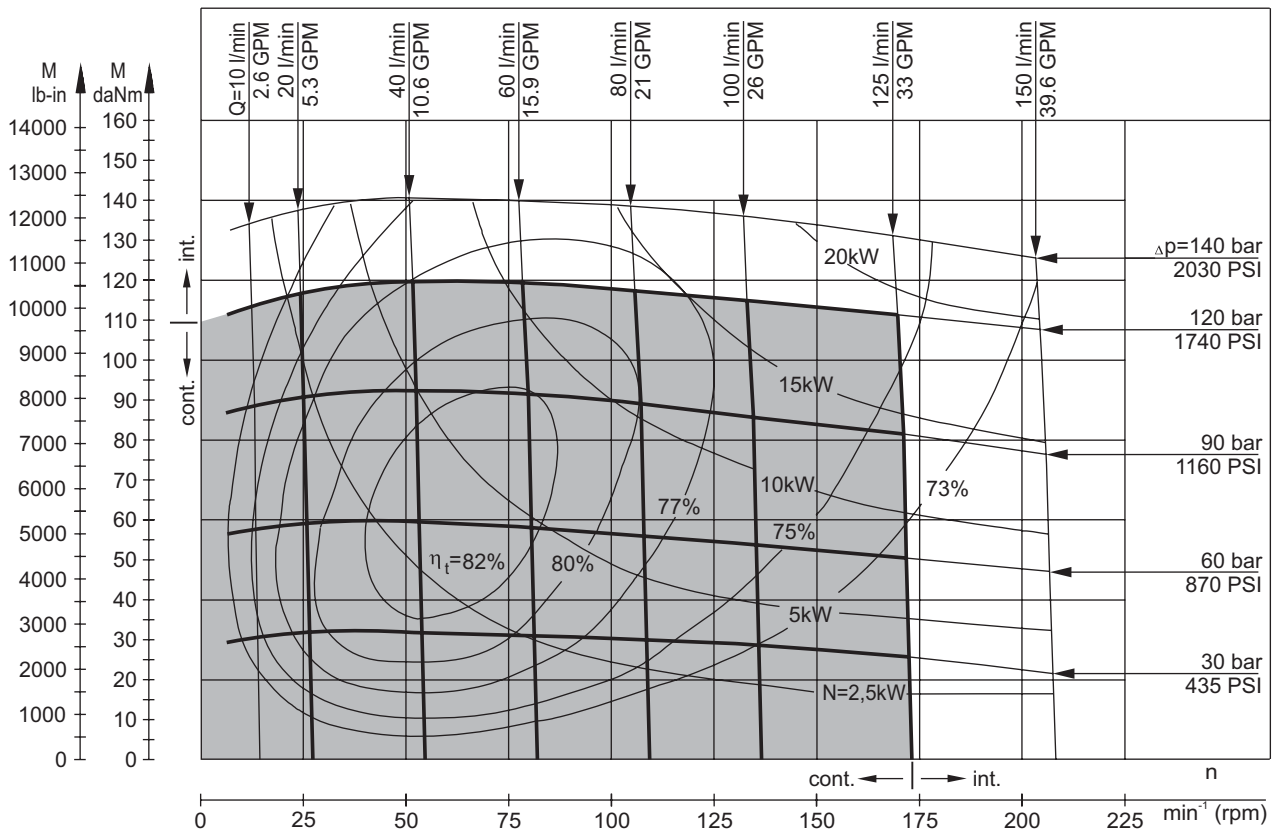

The function diagrams data is for average performance of randomly selected motors at back pressure 5 ± 10 bar [72.5 \pm 145 PSI] and oil with viscosity of 32 mm²/s [150 SUS] at 50°C [122°F].

DIMENSIONS AND MOUNTING DATA

MLHT

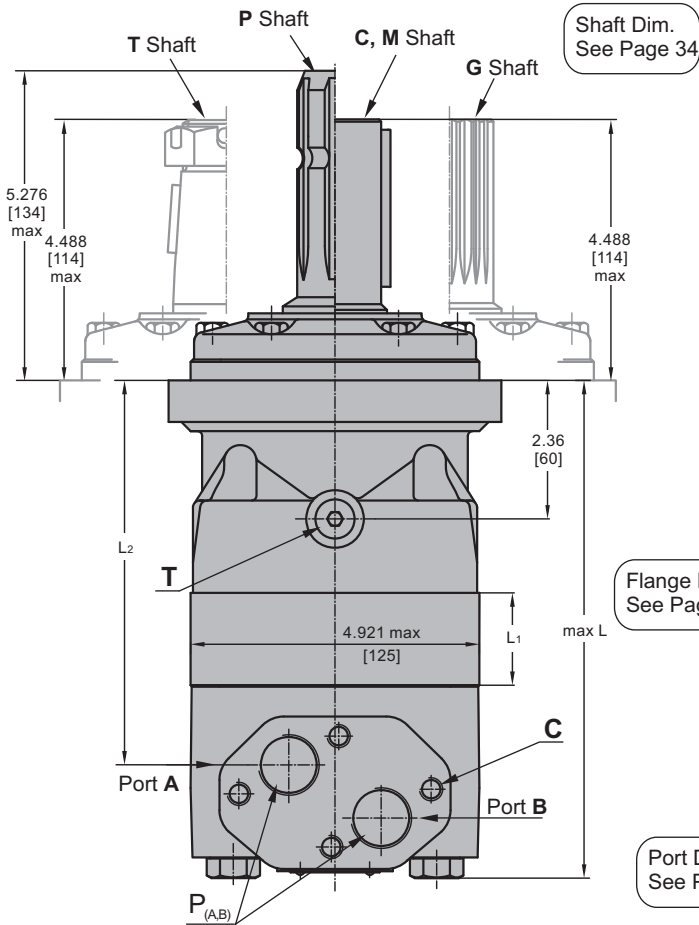

MLHTW

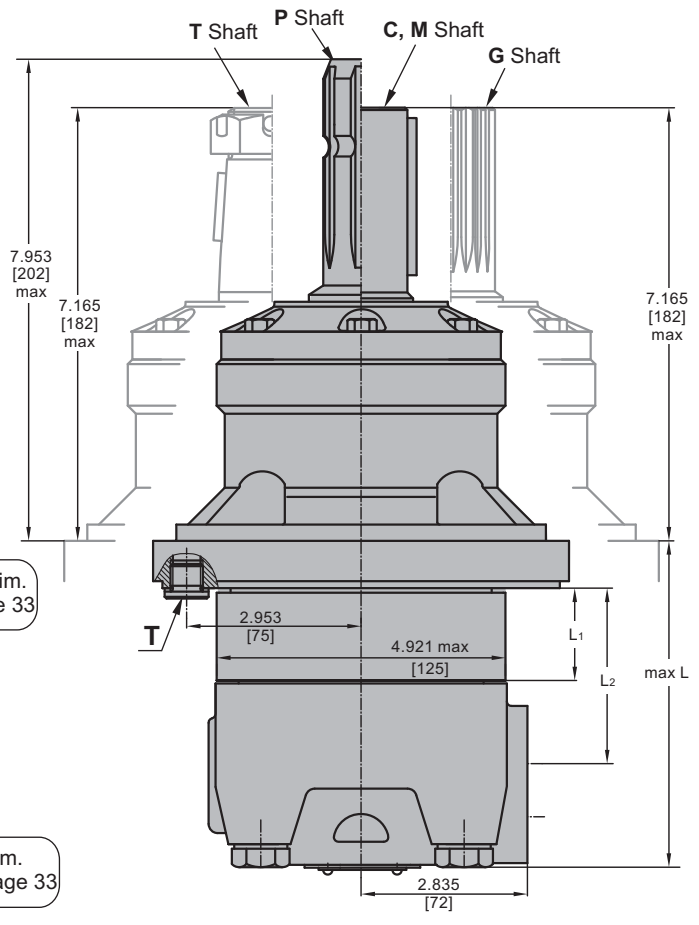

Versions **6** **9**
Rear ports

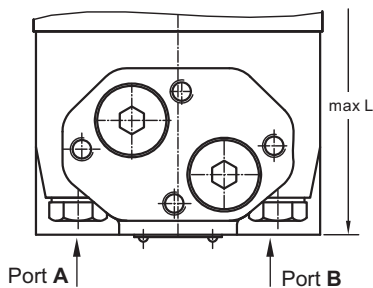

	Versions		
	2,6	3,9	4
C	4xM10	4xM10	-
P (A,B)	2xG ³ / ₄	2xM27x2	2x1 ¹ / ₁₆ -12UN
T	G ¹ / ₄	M14x1,5	⁹ / ₁₆ -18UNF

Standard Rotation

Viewed from Shaft End
Port A Pressurized - **CW**
Port B Pressurized - **CCW**

Reverse Rotation

Viewed from Shaft End
Port A Pressurized - **CCW**
Port B Pressurized - **CW**

Type	L max, in [mm]		L2, in [mm]	Type	L max, in [mm]		L2, in [mm]	**L1, in [mm]
	Versions 2, 3, 4	*Versions 6, 9			Versions 2, 3, 4	*Versions 6, 9		
MLHT 160	7.48 [190]	7.87 [200]	5.51 [140]	MLHTW 160	4.84 [123]	5.23 [133]	2.87 [73]	.65 [16,5]
MLHT 200	7.68 [195]	8.07 [205]	5.71 [145]	MLHTW 200	5.04 [128]	5.43 [138]	3.07 [78]	.85 [21,5]
MLHT 250	7.91 [201]	8.31 [211]	5.95 [151]	MLHTW 250	5.28 [134]	5.67 [144]	3.31 [84]	1.09 [27,8]
MLHT 315	8.31 [211]	8.70 [221]	6.34 [161]	MLHTW 315	5.67 [144]	6.02 [154]	3.70 [94]	1.46 [37,0]
MLHT 400	8.70 [221]	9.09 [231]	6.73 [171]	MLHTW 400	6.06 [154]	6.45 [164]	4.09 [104]	1.87 [47,5]
MLHT 500	9.25 [235]	9.64 [245]	7.28 [185]	MLHTW 500	6.61 [168]	6.61 [178]	4.65 [118]	2.42 [61,5]
MLHT 630	9.09 [231]	9.49 [241]	7.13 [181]	MLHTW 630	6.46 [164]	6.85 [174]	4.49 [114]	2.26 [57,5]
MLHT 725	9.45 [240]	9.84 [250]	7.48 [190]	MLHTW 725	6.81 [173]	7.21 [183]	4.84 [123]	2.62 [66,5]

* -For Rear Ported Motors.

** -The width of the roll-gerotor is .138 in [3,5 mm] greater than L₁.

MOUNTING

SAE C Flange

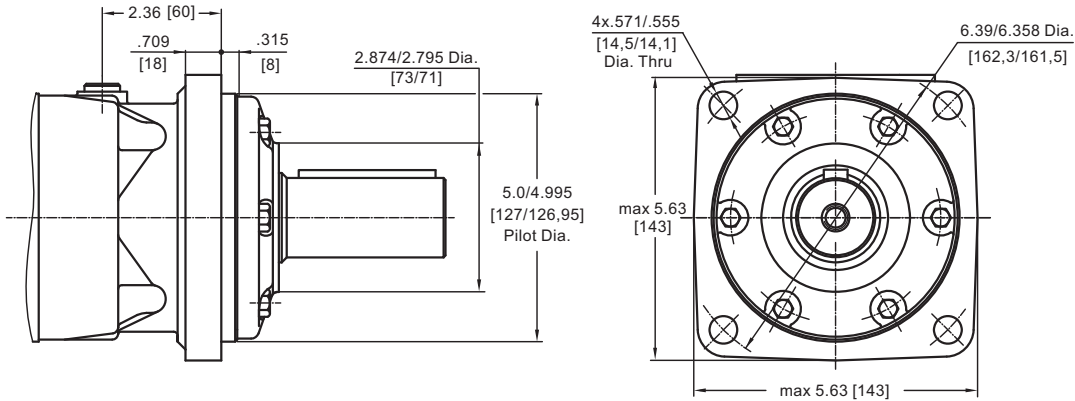

W Wheel Mount

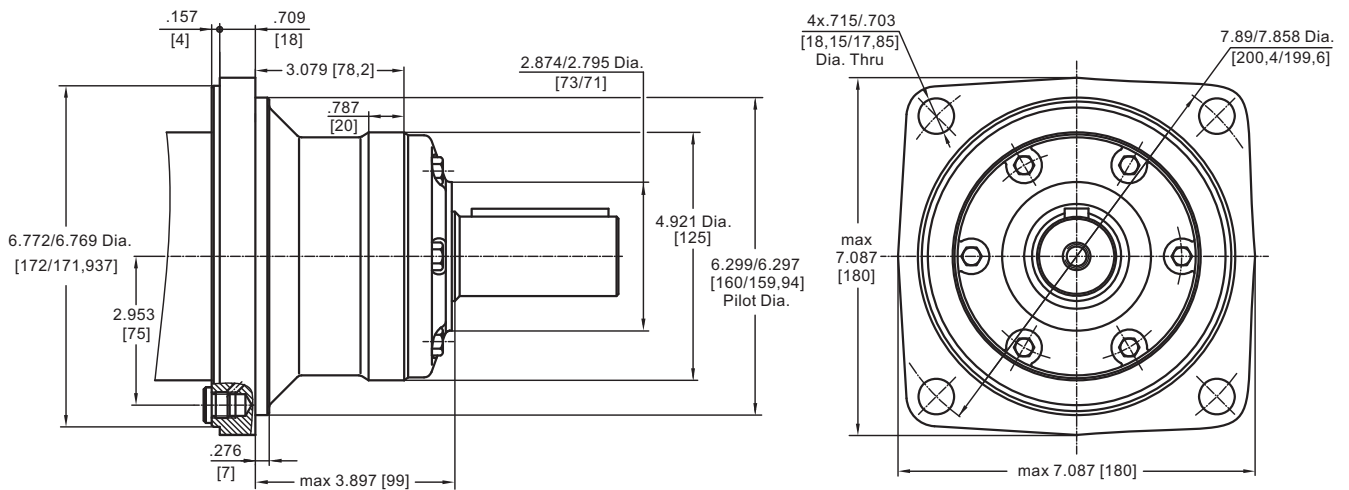

PORTS

**Versions 2 3 4
Side ports**

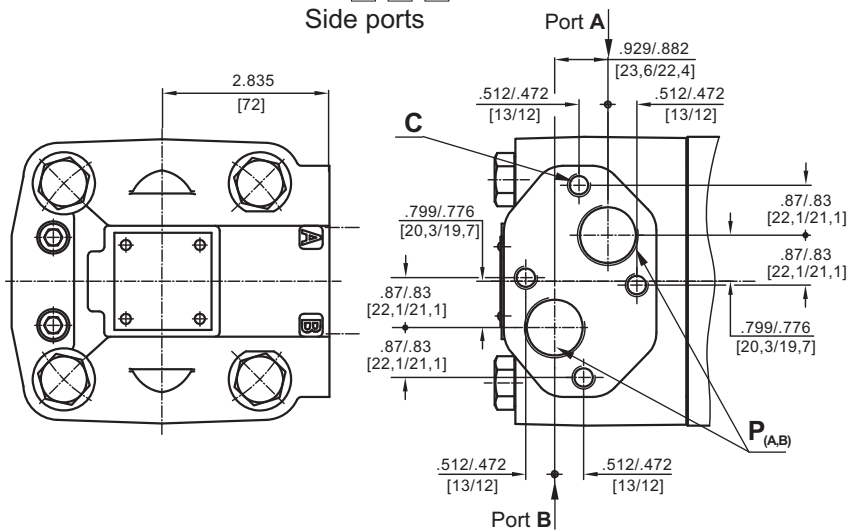

**Versions 6 7 9
Rear ports**

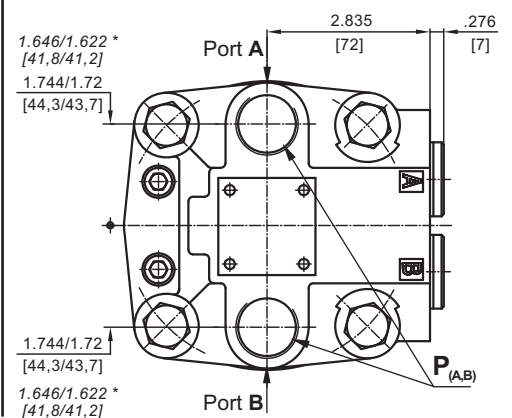

Standard Rotation
Viewed from Shaft End
Port A Pressurized - **CW**
Port B Pressurized - **CCW**

Reverse Rotation
Viewed from Shaft End
Port A Pressurized - **CCW**
Port B Pressurized - **CW**

	Versions		
	2,6	3,9	4,7
C	4xM10	4xM10	-
P (A,B)	2xG ³ / ₄	2xM27x2	2x1 ¹ / ₁₆ -12UN
T	G ¹ / ₄	M14x1,5	9 ¹ / ₁₆ -18UNF

* For Version 7 only!

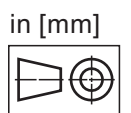

SHAFT EXTENSIONS

C

1½" [38,1] straight, Parallel key ¾" x ¾" x 2¼" BS46
Max. Torque 11750 in-lb [133 daNm]

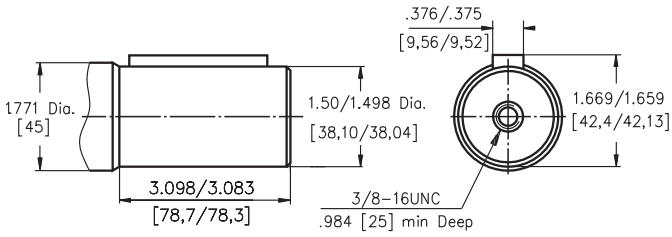

G

17T Splined, 1½" [38,1] ANS B92.1-1976
Max. Torque 11750 in-lb [133 daNm]

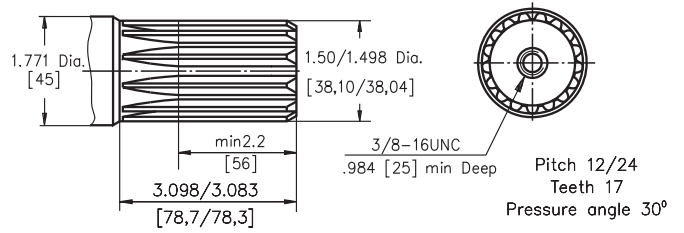

M

ø40 straight, Parallel key A12x8x70 DIN 6885
Max. Torque 11750 in-lb [133 daNm]

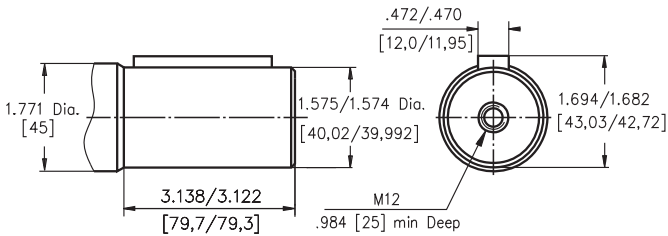

T

SAE J501 Tapered 1:8
Parallel key 7/16" x 7/16" x 1¼" BS46
Max. Torque 18650 in-lb [210 daNm]

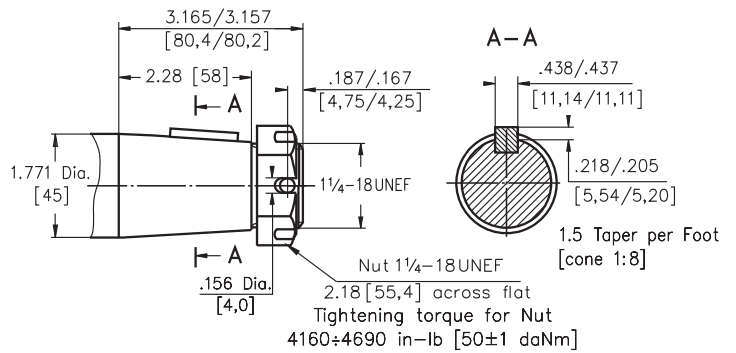

P

ø 34,85 p.t.o. DIN 9611 Form 1
Max. Torque 6815 in-lb [77 daNm]

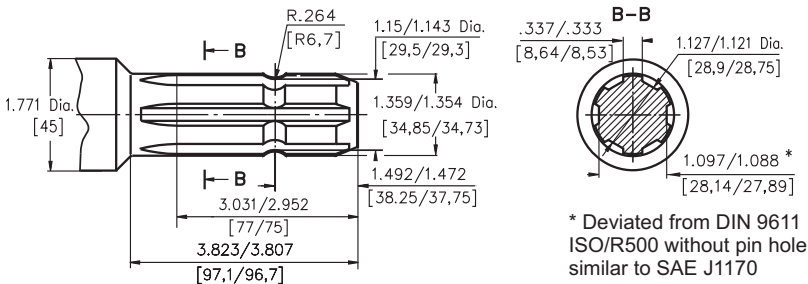

* Deviated from DIN 9611 ISO/R500 without pin hole similar to SAE J1170



Required max. Torque must not be exceeded.

MAX. PERMISSIBLE SHAFT SEAL PRESSURE

Max. return pressure without drain line or max. pressure in the drain line

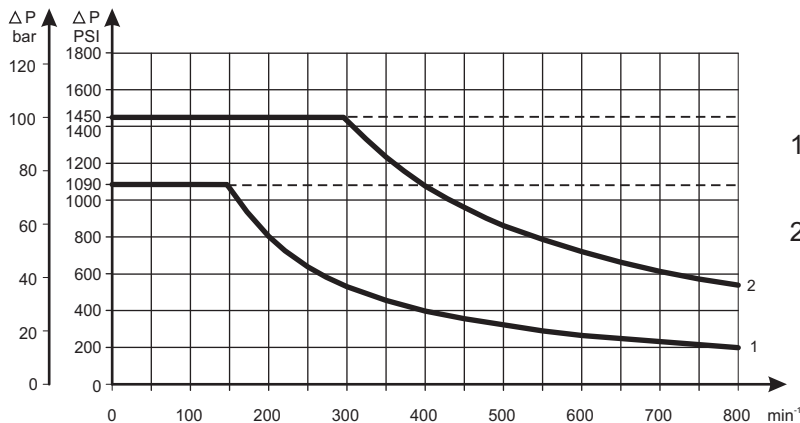

1: Drawing for Standard Shaft Seal

2: Drawing for High Pressure Seal ("U" Seal)

— - continuous operations
- - - - intermittent operations

DIMENSIONS AND MOUNTING DATA - MLHTS and MLHTV

S Short Mount

V Very Short Mount

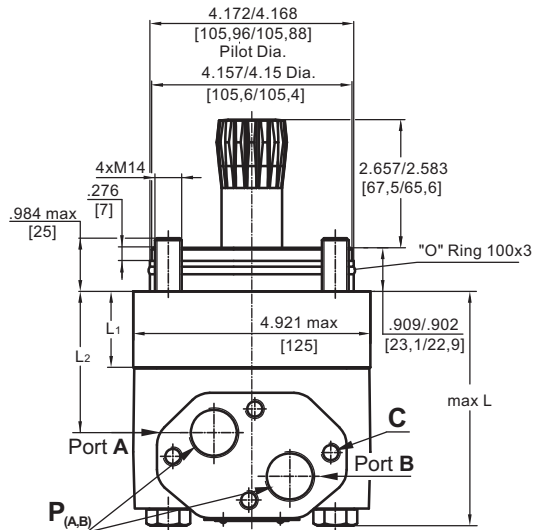
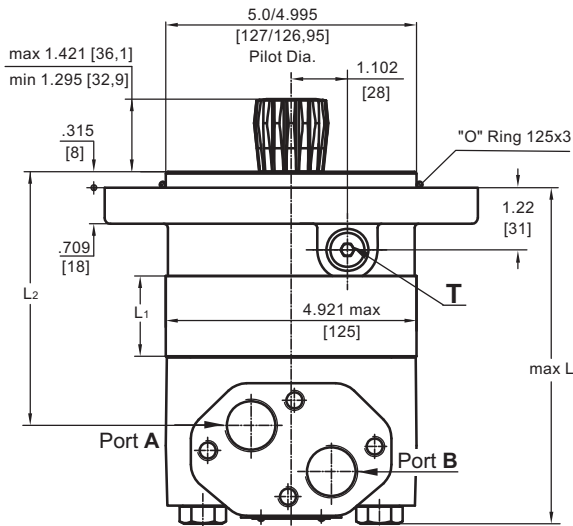
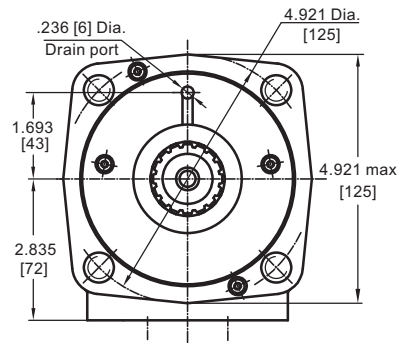
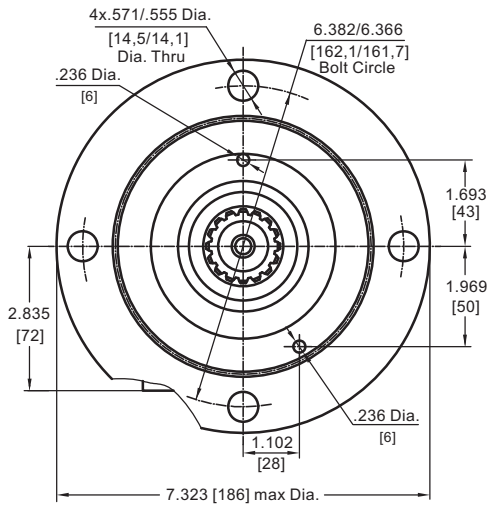

Port Dim.
See Page 33

Versions **6** **9**

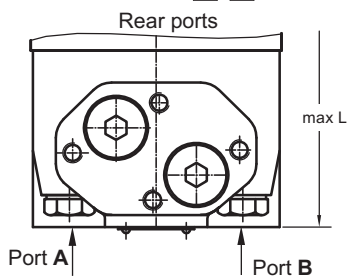

Standard Rotation
Viewed from Shaft End
Port A Pressurized - CW
Port B Pressurized - CCW

Reverse Rotation
Viewed from Shaft End
Port A Pressurized - CCW
Port B Pressurized - CW



	Versions		
	2,6	3,9	4
C	4xM10	4xM10	-
P (A,B)	2xG ³ / ₄	2xM27x2	2x1 ¹ / ₁₆ -12UN
T	G ¹ / ₄	M14x1,5	9 ¹ / ₁₆ -18UNF

Type	L max, in [mm]		L2, in [mm]	Type	L max, in [mm]		L2, in [mm]	**L1, in [mm]
	Versions 2, 3, 4	*Versions 6, 9			Versions 2, 3, 4	*Versions 6, 9		
MLHTS 160	5.75 [146]	6.14 [156]	3.78 [96]	MLHTV 160	3.98 [101]	4.37 [111]	2.02 [51,5]	.65 [16,5]
MLHTS 200	5.95 [151]	6.33 [161]	3.98 [101]	MLHTV 200	4.17 [106]	4.57 [116]	2.22 [56,5]	.85 [21,5]
MLHTS 250	6.18 [157]	6.57 [167]	4.21 [107]	MLHTV 250	4.41 [112]	4.80 [122]	2.47 [62,8]	1.09 [27,8]
MLHTS 315	6.53 [166]	6.93 [176]	4.56 [116]	MLHTV 315	4.76 [121]	5.16 [131]	2.83 [72,0]	1.46 [37,0]
MLHTS 400	6.97 [177]	7.36 [187]	5.00 [127]	MLHTV 400	5.19 [132]	5.59 [142]	3.25 [82,5]	1.87 [47,5]
MLHTS 500	7.52 [191]	7.91 [201]	5.59 [142]	MLHTV 500	5.75 [146]	6.14 [156]	3.80 [96,5]	2.42 [61,5]
MLHTS 630	7.36 [187]	7.76 [197]	5.43 [138]	MLHTV 630	5.59 [142]	5.98 [152]	3.64 [92,5]	2.26 [57,5]
MLHTS 725	7.72 [196]	8.11 [206]	5.79 [147]	MLHTV 725	5.95 [151]	6.34 [161]	4.00 [101,5]	2.62 [66,5]

* - For Rear Ported Motors.

** - The width of the roll-gerotor is .138 in. [3,5 mm] greater than L₁.

DIMENSIONS OF THE ATTACHED COMPONENT

For MLHTS

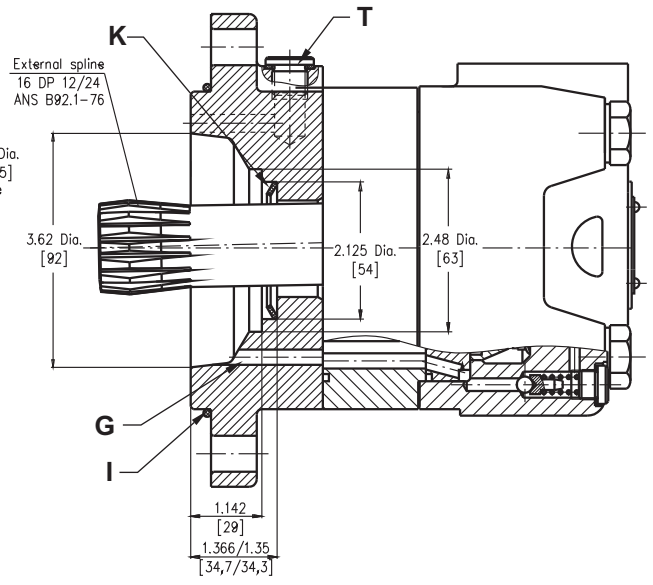
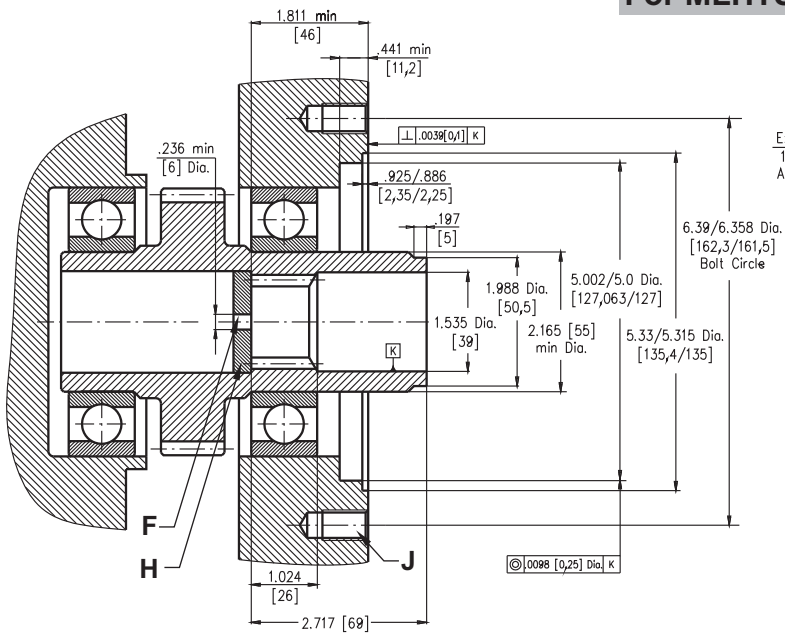

- F:** Oil circulation hole
- G:** Internal drain channel
- H:** Hardened stop plate

- J:** 4x1/2UN; .71 [18] Deep, 90°, 6.375 [162] Dia. B. C.
- K:** Conical seal ring
- T:** Drain connection G1/4, M14x1,5 or 9/16 - 18UNF

For MLHTV

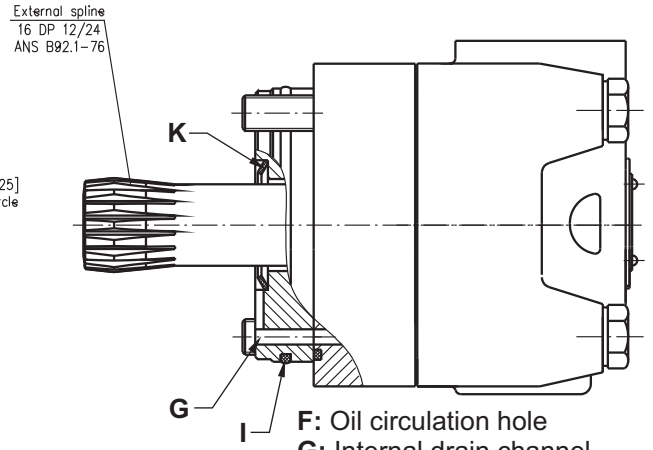
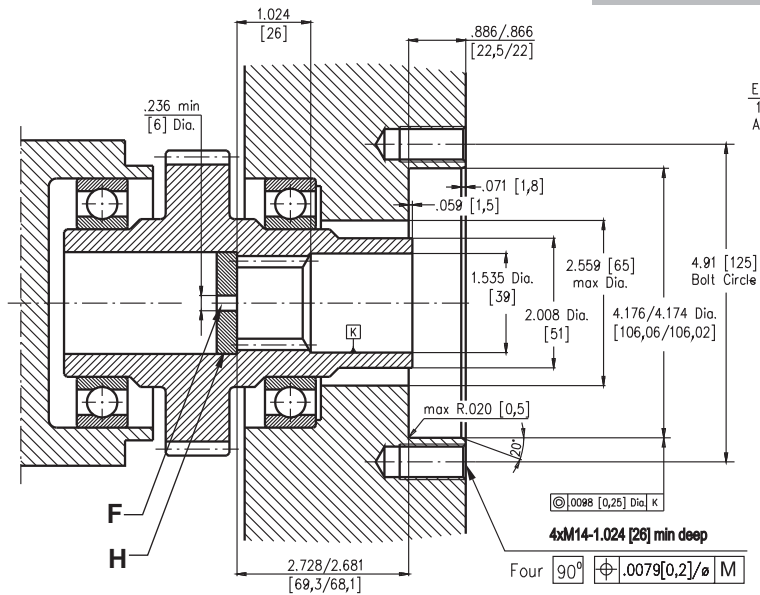

- F:** Oil circulation hole
- G:** Internal drain channel
- H:** Hardened stop plate
- I:** O-Ring 3.94x.118 [100x3]
- K:** Conical seal ring

DRAIN CONNECTION

A drain line has to be used when pressure in the return line can exceed the permissible pressure. It can be connected:

- For MLHTS at the drain port of the motor;
- For MLHTV at the drain connection of the attached component. The maximum pressure in the drain line is limited by the attached component and its shaft seal.

The drain line must be possible for oil to flow freely between motor and attached component and must be led to the tank. The maximum pressure in the drain line is limited by the attached component and its seal.

INTERNAL SPLINE DATA FOR THE ATTACHED COMPONENT

Standard ANS B92.1-1976, class 5
[$m=2.1166$; corrected $x.m=1$]

Fillet Root Side Fit		inch	mm
Number of Teeth	z	16	16
Diametral Pitch	DP	12/24	12/24
Pressure Angle		30°	30°
Pitch Dia.	D	1.3333	33,8656
Major Dia.	D_{ri}	1.5118÷1.5275	38,4 ^{+0,4}
Minor Dia.	D_i	1.2657÷1.2673	32,15 ^{+0,04}
Space Width [Circular]	L_o	.1763÷.1791	4,516±0,037
Fillet Radius	R	.02	0,5
Max. Measurement between Pins	L	1.063÷1.059	26,9 ^{+0,10}
Pin Dia.	d	.19026÷.19034	4,835±0,001

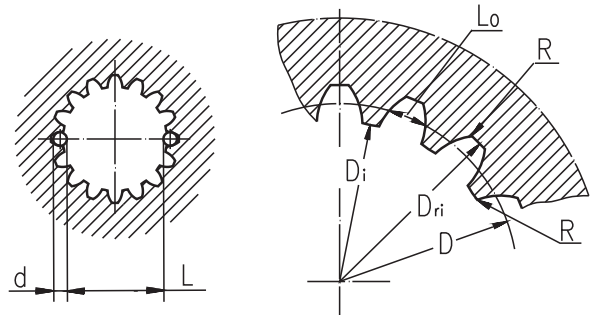

Hardening Specification:
 HV=750±50 on the surface.
 HV=560 at .035±.019 [0,7±0,2] case depth
 Material: 20 MoCr4 EN 10084 or SAE8620.

PERMISSIBLE SHAFT LOADS

The output shaft runs in tapered bearings that permit high axial and radial forces. The permissible radial load on the shaft is shown for an axial load of 0 N as function of the distance from the mounting flange to the point of load application. The curves apply to a B10 bearing life of 2000 hours at 100 RPM .

Curve "1" shows max. radial shaft load. Any shaft load exceeding the values shown by the curve will seriously reduce motor life.

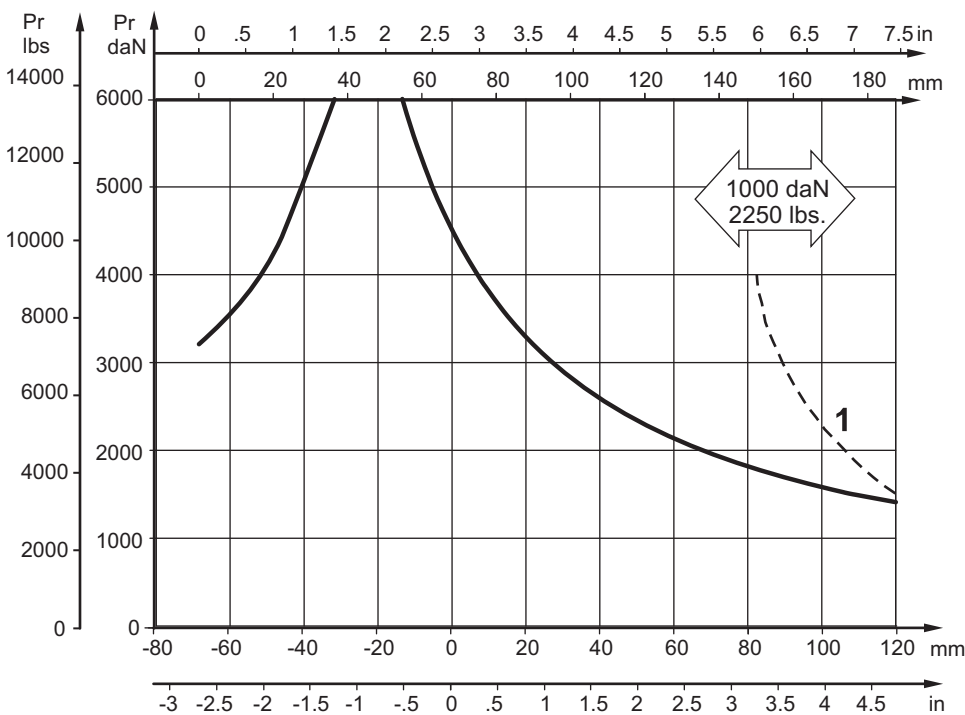

Mounting Flange:

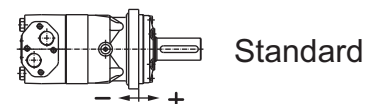

MOTORS WITH TACHO CONNECTION

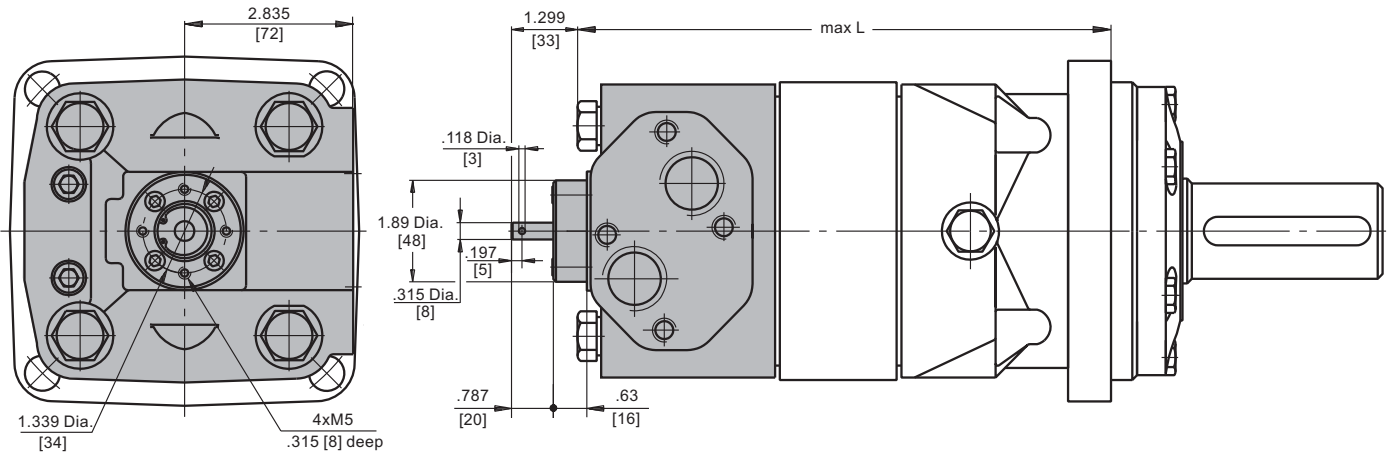

ORDER CODE

	1	2	3	4	5	6	7
MLHT							

Pos.1 - Mounting Flange

omit - SAE C, four holes

S - Short

V - Very short

W - Wheel mount

Pos.2 - Displacement code

160	- 9.83 [61,6] in ³ /rev [cm ³ /rev]
200	- 12.29 [201,4] in ³ /rev [cm ³ /rev]
250	- 15.36 [251,8] in ³ /rev [cm ³ /rev]
315	- 19.90 [326,3] in ³ /rev [cm ³ /rev]
400	- 25.06 [410,9] in ³ /rev [cm ³ /rev]
500	- 31.95 [523,6] in ³ /rev [cm ³ /rev]
630	- 38.52 [631,2] in ³ /rev [cm ³ /rev]
725	- 44.20 [724,3] in ³ /rev [cm ³ /rev]

Pos.3 - Shaft Extensions*

omit - for **S** and **V** mounting flange

C - 1 1/2" [38,10] straight, Parallel key

G - 1 1/2" [38,10] 17T Splined

M - 40 mm straight, Parallel key

P - 34,85 mm Splined, p.t.o. DIN 9611 Form 1

T - 1 3/4" [44,50] J501 Tapered

Pos.4 - Port Size/Type [standard manifold to each]

2 - side ports, 2xG³/₄, G¹/₄, BSP thread, ISO 228

3 - side ports, 2xM27x2; M14x1,5; metric thread,ISO 262

4 - side ports, 2x 1 1/16-12 UN, O-ring, 9/16-18 UNF

6 - rear ports, 2xG³/₄, G¹/₄; BSP thread, ISO 228

7 - rear ports, 2x 1 1/16-12 UN, O-ring, 9/16-18 UNF

9 - rear ports, 2xM27x2; M14x1,5; metric thread,ISO 262

Pos.5 - Shaft Seal Version [see page 34]

omit - Low pressure seal

U - High pressure seal

Pos.6 - Special Features [see page 51]

Pos.7 - Design Series

omit - Factory specified

Notes: * The permissible output torque for shafts must not be exceeded!

The hydraulic motors are mangano-phosphatized as standard.

HYDRAULIC MOTORS MLHV



APPLICATION

- » Conveyors
- » Metal working machines
- » Agricultural machines
- » Road building machines
- » Mining machinery
- » Food industries
- » Special vehicles
- » Plastic and rubber machinery etc.

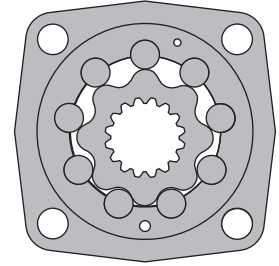
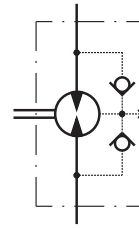

CONTENTS

Specification data	40
Performance data	41÷43
Permissible shaft loads	43
Dimensions and mounting MLHV, C, W.....	44÷46
Dimensions and mounting- MLHVS.....	47
Dimensions and mounting- MLHVV.....	48
Internal Spline data	49
Tacho connection.....	49
Shaft extensions	50
Order code	50

OPTIONS

- » Model - Disc valve, roll-gerotor
- » Flange and wheel mount
- » Short motor
- » Tacho connection
- » Speed sensing
- » Side ports
- » Shafts - straight, splined and tapered
- » SAE and BSPP ports
- » Other special features

GENERAL

Max. Displacement, in ³ /rev [cm ³ /rev]	48.91 [801,8]
Max. Speed, [RPM]	630
Max. Torque, lb-in [daNm]	cont.: 16650 [188] int.: 18650 [211]
Max. Output, HP [kW]	85,8 [64]
Max. Pressure Drop, PSI [bar]	cont.: 2900 [200] int.: 3480 [240]
Max. Oil Flow, GPM [lpm]	63.4 [240]
Min. Speed, [RPM]	5
Permissible Shaft Loads lbs [daN]	P _a =3300 [1500]
Pressure fluid	Mineral based- HLP(DIN 51524) or HM(ISO 6743/4)
Temperature range, °F [°C]	-40÷284 [-40÷140]
Optimal Viscosity range, SUS [mm²/s]	98÷347 [20÷75]
Filtration	ISO code 20/16 (Min. recommended fluid filtration of 25 microns)

Oil flow in drain line

Pressure drop PSI [bar]	Viscosity SUS [mm ² /s]	Oil flow in drain line GPM [lpm]
2030 [140]	98 [20]	.793 [3]
	164 [35]	.528 [2]
3045 [210]	98 [20]	.1.585 [6]
	164 [35]	1.057 [4]

Pressure Losses

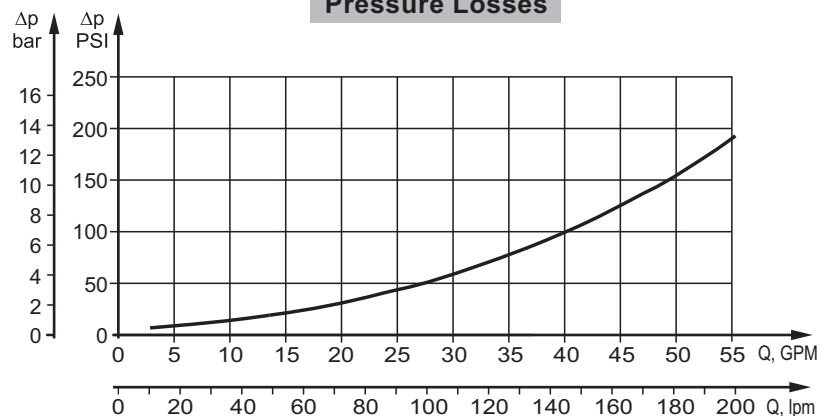

SPECIFICATION DATA

Type		MLHV 315	MLHV 400	MLHV 500	MLHV 630	MLHV 800
Displacement, in³/rev [cm³/rev]		19.18 [314,5]	24.45 [400,9]	30.48 [499,6]	38.38 [629,1]	48.91 [801,8]
Max. Speed, [RPM]	Cont.	510	500	400	320	250
	Int.*	630	600	480	380	300
Max. Torque lb-in [daNm]	Cont.	8150 [92]	10450 [118]	12950 [146]	14700 [166]	16650 [188]
	Int.*	9800 [111]	12500 [141]	15550 [176]	17150 [194]	18650 [211]
	Peak**	11400 [129]	14500 [164]	18150 [205]	19550 [221]	21850 [247]
Max. Output HP [kW]	Cont.	57 [42,5]	71.7 [53,5]	71.7 [53,5]	64.4 [48]	57 [42,5]
	Int.*	68,4 [51]	85.8 [64]	85.8 [64]	75 [56]	64.4 [48]
Max. Pressure Drop PSI [bar]	Cont.	2900 [200]	2900 [200]	2900 [200]	2600 [180]	2320 [160]
	Int.*	3480 [240]	3480 [240]	3480 [240]	3050 [210]	2610 [180]
	Peak**	4060 [280]	4060 [280]	4060 [280]	3480 [240]	3050 [210]
Max. Oil Flow GPM [lpm]	Cont.	42.3 [160]	52.8 [200]	52.8 [200]	52.8 [200]	52.8 [200]
	Int.*	52.8 [200]	63.4 [240]	63.4 [240]	63.4 [240]	63.4 [240]
Max. Inlet Pressure PSI [bar]	Cont.	3050 [210]	3050 [210]	3050 [210]	3050 [210]	3050 [210]
	Int.*	3620 [250]	3620 [250]	3620 [250]	3620 [250]	3620 [250]
	Peak**	4350 [300]	4350 [300]	4350 [300]	4350 [300]	4350 [300]
Max. Return Pressure with Drain Line PSI [bar]	Cont.	2040 [140]	2040 [140]	2040 [140]	2040 [140]	2040 [140]
	Int.*	2540 [175]	2540 [175]	2540 [175]	2540 [175]	2540 [175]
	Peak**	3050 [210]	3050 [210]	3050 [210]	3050 [210]	3050 [210]
Max. Starting Pressure with Unloaded Shaft, PSI [bar]		120 [8]	120 [8]	120 [8]	120 [8]	120 [8]
Min. Starting Torque lb-in [daNm]	At max. press. drop Cont.	6300 [71]	8100 [91]	10000 [113]	11800 [133]	13400 [151]
	At max. press. drop Int.*	7500 [85]	9600 [109]	12000 [136]	13700 [155]	15000 [170]
Min. Speed***, [RPM]		10	10	10	10	10
Weight, lb [kg]	MLHV	67.7 [30,7]	69.5 [31,5]	71.4 [32,4]	74.1 [33,6]	77.6 [35,2]
	MLHVW	69.2 [31,4]	71.0 [32,2]	73.0 [33,1]	75.6 [34,3]	79.2 [35,9]
	MLHVS	49.2 [22,3]	50.9 [23,1]	52.9 [24,0]	55.6 [25,2]	59.1 [26,8]

* Intermittent operation: the permissible values may occur for max. 10% of every minute.

** Peak load: the permissible values may occur for max. 1% of every minute.

*** For speeds lower than given, consult factory or your regional manager.

1. Intermittent speed and intermittent pressure drop must not occur simultaneously.
2. Recommended filtration is per ISO cleanliness code 20/16. A nominal filtration of 25 micron or better.
3. Recommend using a premium quality, anti-wear type mineral based hydraulic oil HLP(DIN51524) or HM (ISO 6743/4).
If using synthetic fluids consult the factory for alternative seal materials.
4. Recommended minimum oil viscosity 70 SUS [13 mm²/s] at 122°F [50°C].
5. Recommended maximum system operating temperature is 180°F [82°C].
6. To assure optimum motor life fill with fluid prior to loading and run at moderate load and speed for 10-15 minutes.

FUNCTION DIAGRAMS

MLHV 315

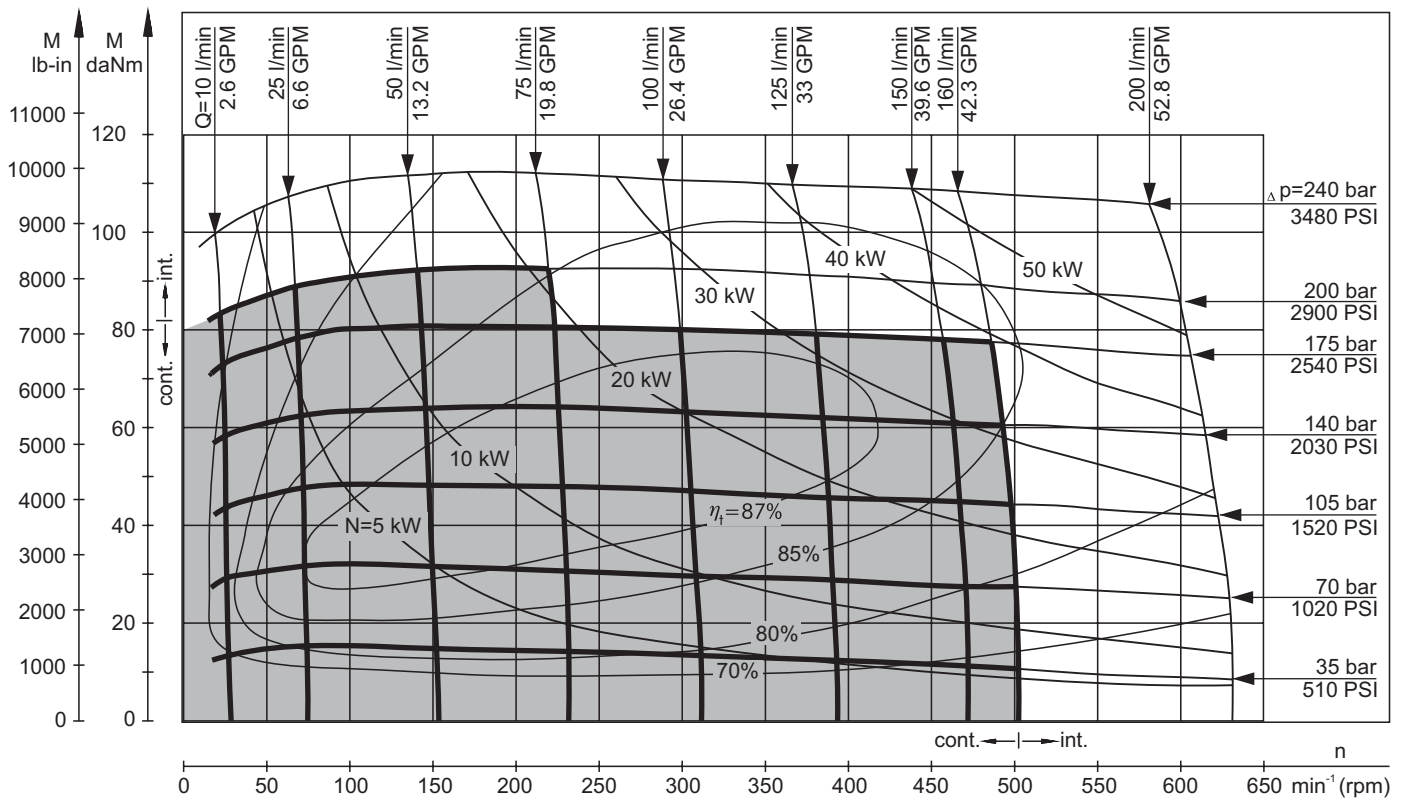

MLHV 400

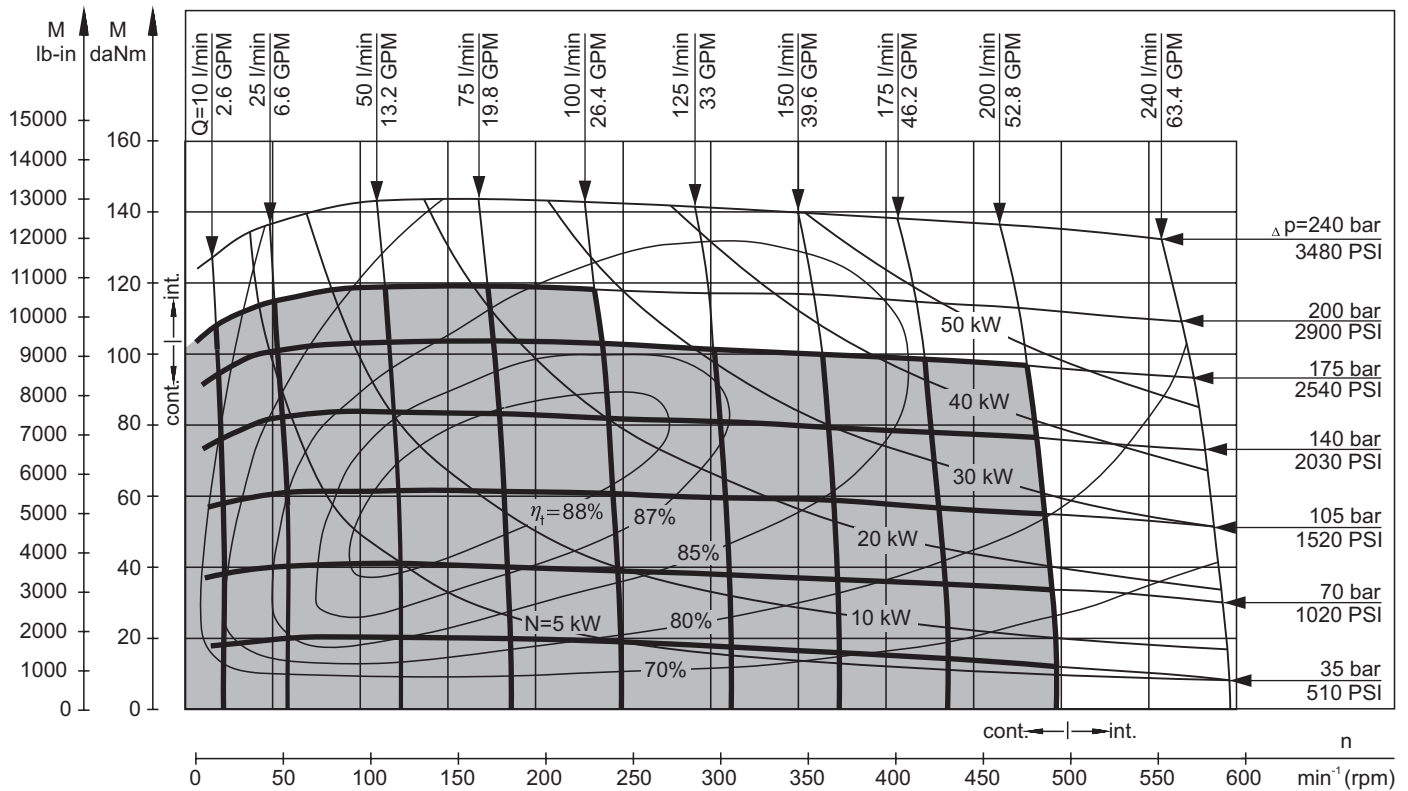

The function diagrams data is for average performance of randomly selected motors at back pressure 72.5÷145 PSI [5÷10 bar] and oil with viscosity of 150 SUS [32 mm²/s] at 122°F [50°C].

FUNCTION DIAGRAMS

MLHV 500

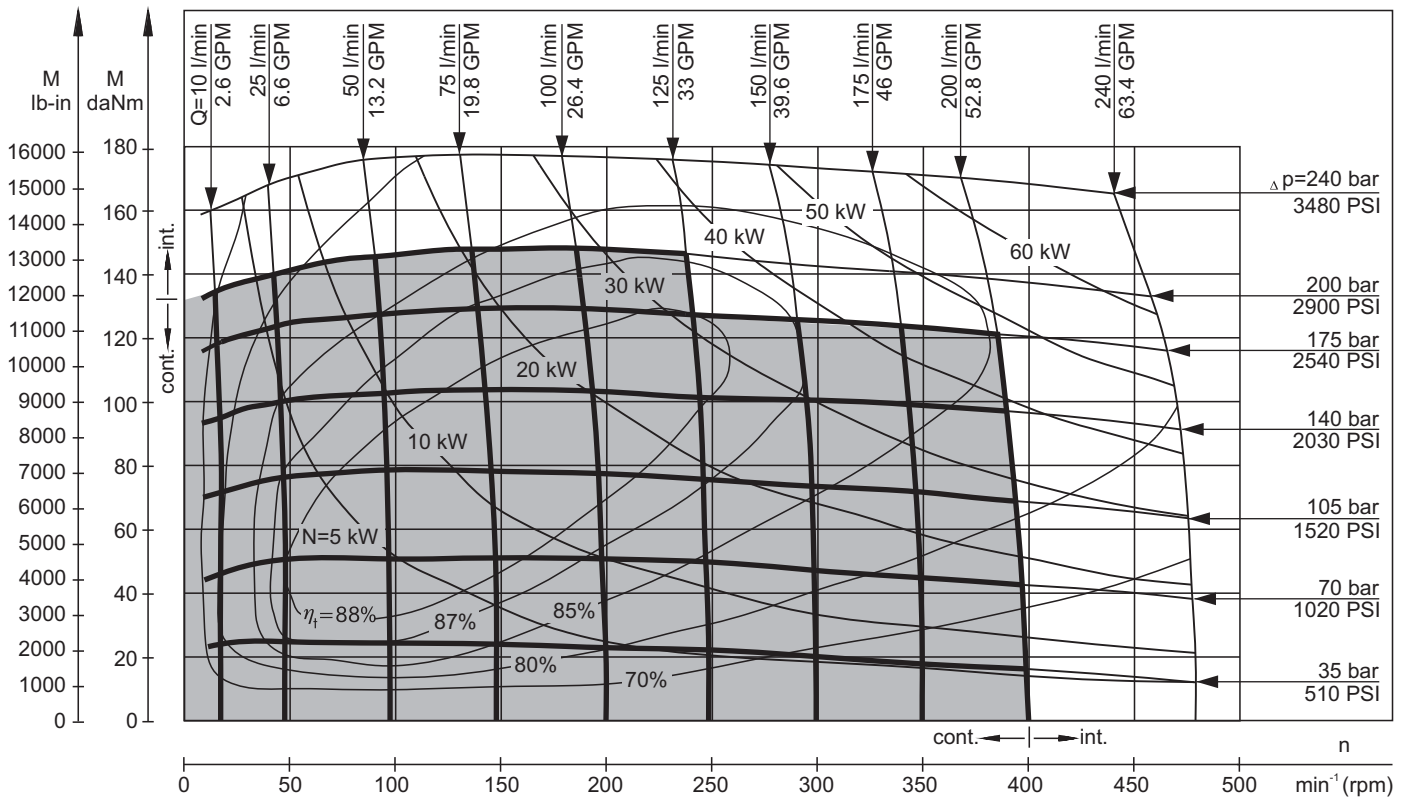

MLHV 630

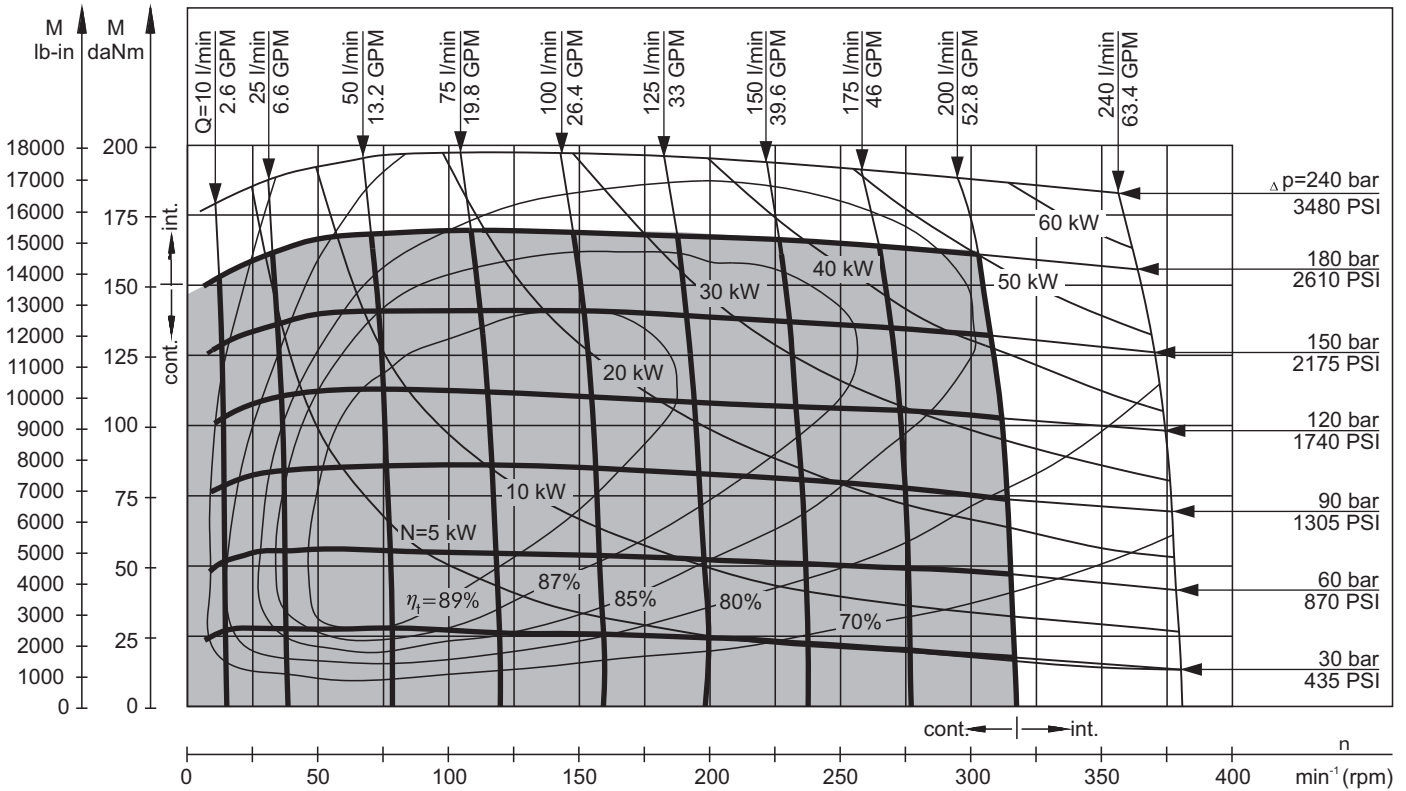

The function diagrams data is for average performance of randomly selected motors at back pressure 72.5÷145 PSI [5÷10 bar] and oil with viscosity of 150 SUS [32 mm²/s] at 122°F [50°C].

FUNCTION DIAGRAMS

MLHV 800

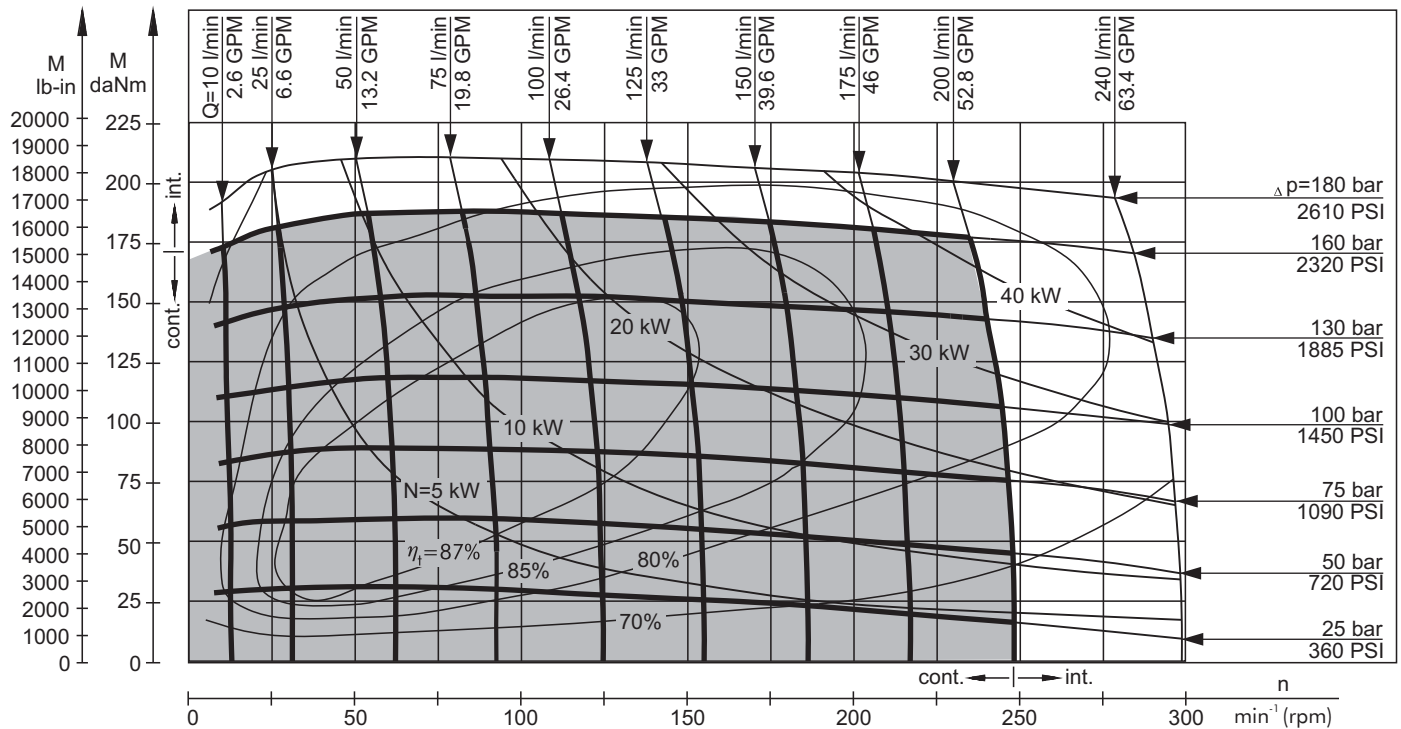

The function diagrams data is for average performance of randomly selected motors at back pressure 72.5÷145 PSI [5÷10 bar] and oil with viscosity of 150 SUS [32 mm²/s] at 122°F [50°C].

PERMISSIBLE SHAFT LOADS

The output shaft runs in tapered bearings that permit high axial and radial forces. The permissible radial load on the shaft is shown for an axial load of 0 N as function of the distance from the mounting flange to the point of load application. The curves apply to a B10 bearing life of 2000 hours at 100 RPM.

Curve "1" shows max. radial shaft load. Any shaft load exceeding the values shown by the curve will seriously reduce motor life.

Mounting Flange:

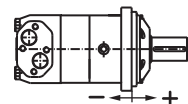
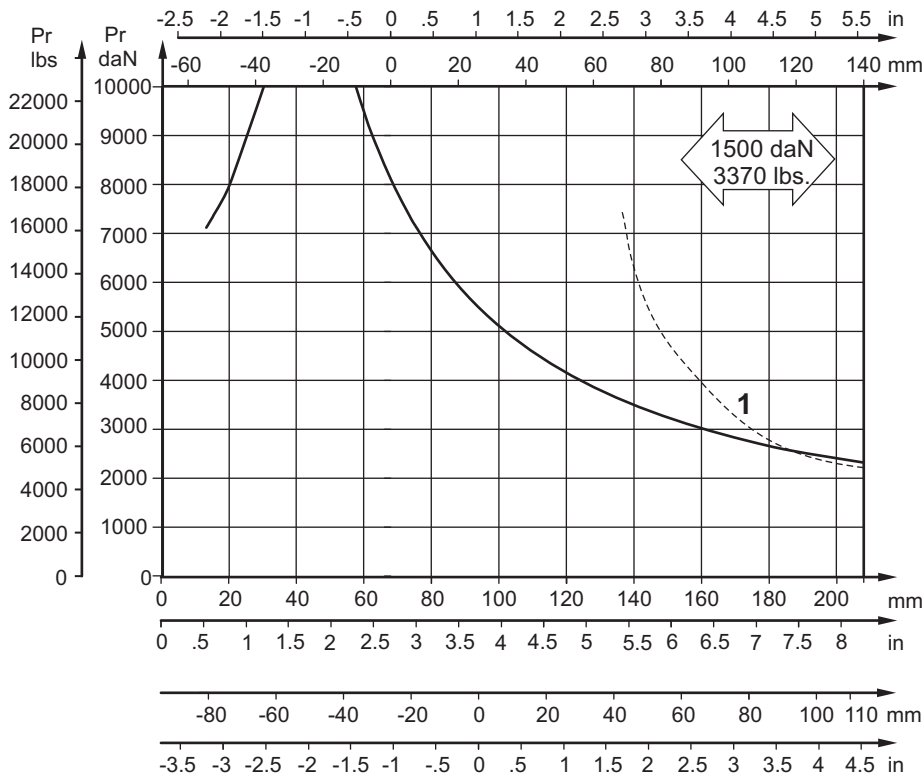

Standard

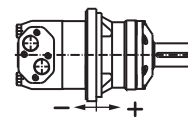

W - Wheel

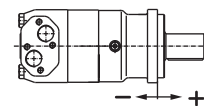

C - Flange

DIMENSIONS AND MOUNTING DATA - MLHV and MLHVC

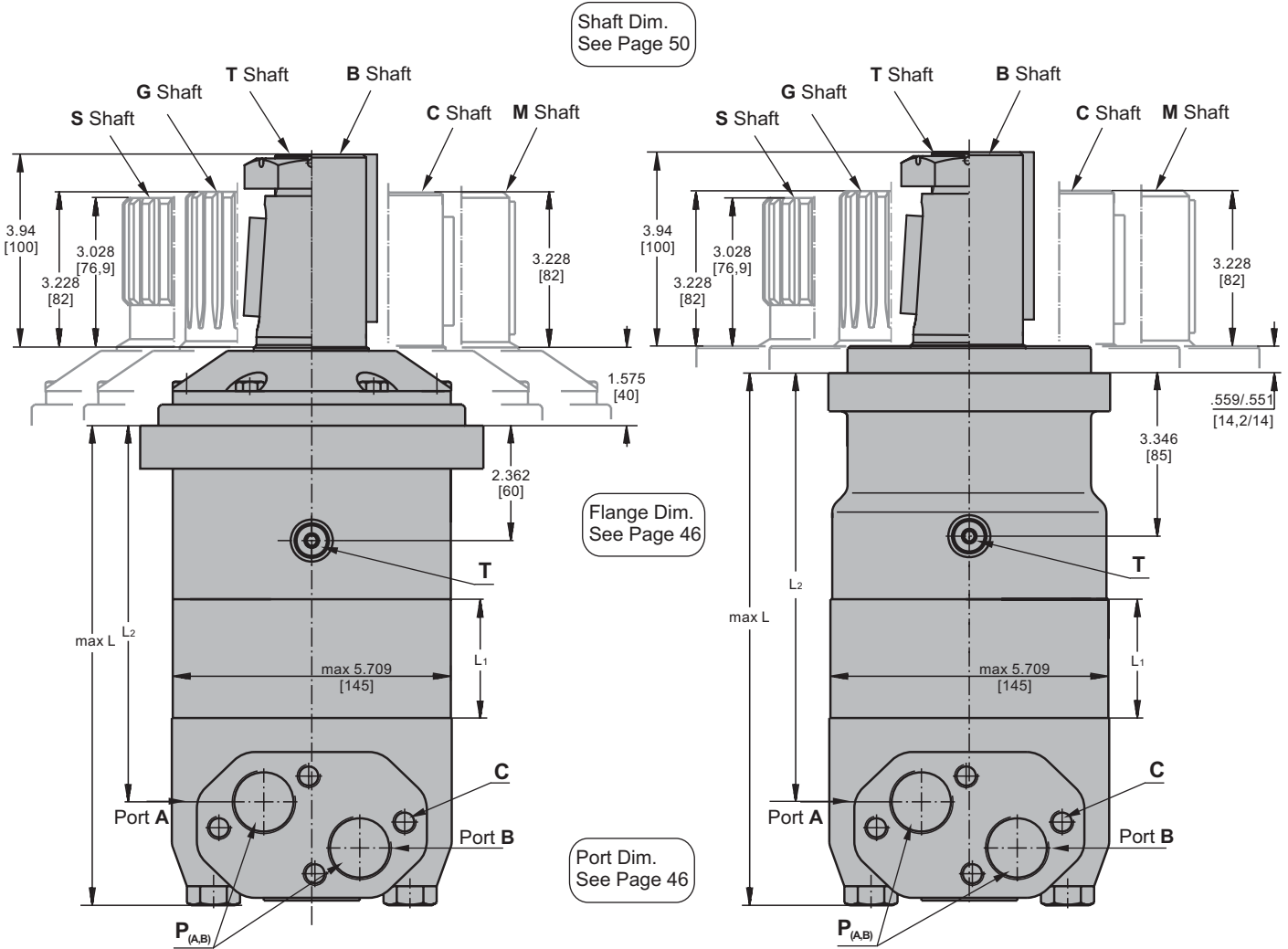

Standard Rotation
Viewed from Shaft End
Port A Pressurized - CW
Port B Pressurized - CCW

Reverse Rotation
Viewed from Shaft End
Port A Pressurized - CCW
Port B Pressurized - CW

	Versions	
	2	4
C	4xM12	-
P (A,B)	2xG1	2x1 ⁵ / ₁₆ -12UN
T	G ¹ / ₄	⁹ / ₁₆ -18UNF



Type	L, in [mm]	L2, in [mm]	Type	L, in [mm]	L2, in [mm]	*L1, in [mm]
MLHV 315	8.45[214,5]	6.30[160]	MLHVC 315	9.38[238,25]	7.25[184,26]	.87 [22,0]
MLHV 400	8.72[221,5]	6.58[167]	MLHVC 400	9.66[245,25]	7.53[191,26]	1.14 [29,0]
MLHV 500	9.04[229,5]	6.89[175]	MLHVC 500	9.97[253,25]	7.85[199,26]	1.46 [37,0]
MLHV 630	9.45[240,0]	7.32[186]	MLHVC 630	10.38[263,75]	8.25[209,76]	1.87 [47,5]
MLHV 800	10.0[254,0]	7.87[200]	MLHVC 800	10.94[277,75]	8.81[223,76]	2.42 [61,5]

* The width of the gerolor is .157 in. [4 mm] greater than L₁.

DIMENSIONS AND MOUNTING DATA - MLHVW

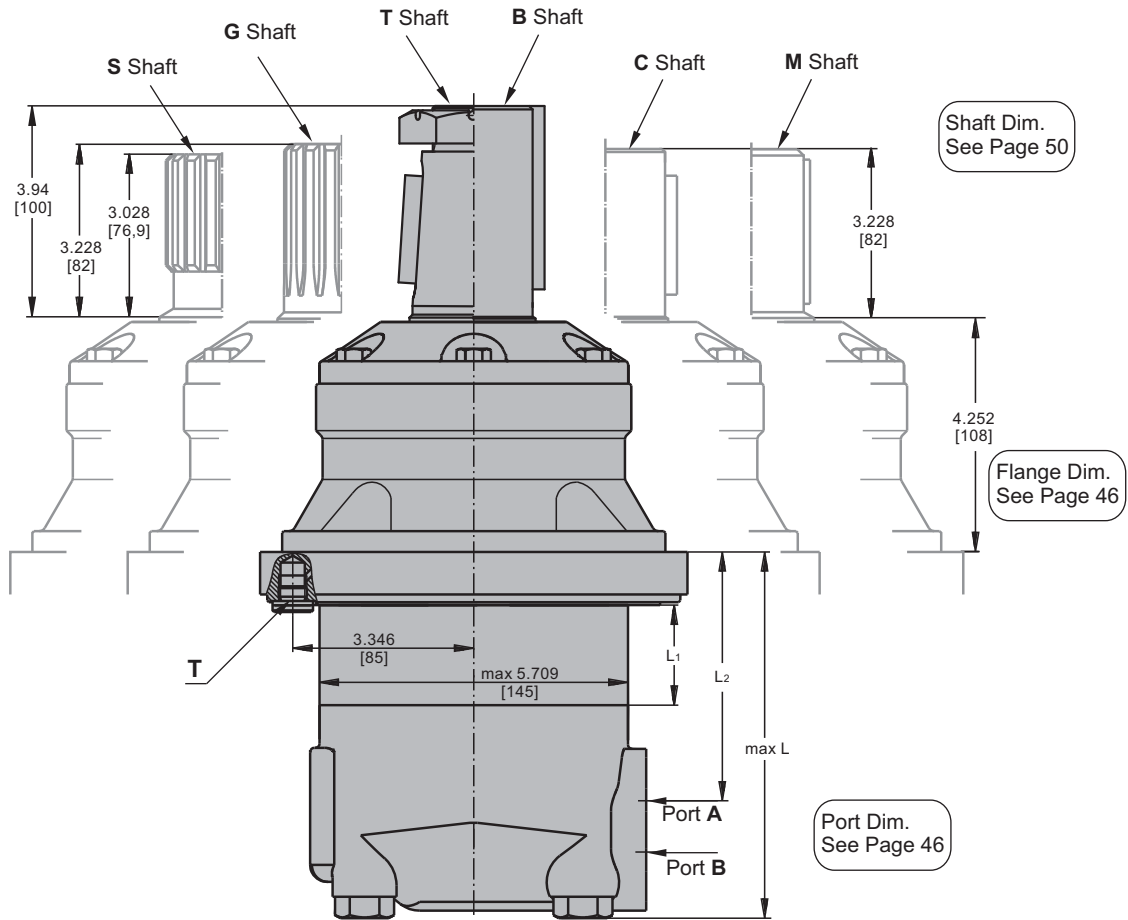

Standard Rotation
Viewed from Shaft End
Port A Pressurized - **CW**
Port B Pressurized - **CCW**

Reverse Rotation
Viewed from Shaft End
Port A Pressurized - **CCW**
Port B Pressurized - **CW**

	Versions	
	2	4
C	4xM12	-
P (A,B)	2xG1	2x1 ⁵ / ₁₆ -12UN
T	G ¹ / ₄	⁹ / ₁₆ -18UNF



Type	L, in [mm]	L2, in [mm]	*L ₁ , in [mm]
MLHVW 315	5.75 [146]	3.62 [92]	.87 [22,0]
MLHVW 400	6.02 [153]	3.90 [99]	1.14 [29,0]
MLHVW 500	6.34 [161]	4.21 [107]	1.46 [37,0]
MLHVW 630	6.77 [172]	4.65 [118]	1.87 [47,5]
MLHVW 800	7.28 [185]	5.20 [132]	2.42 [61,5]

* The width of the gerotor is .157 in. [4 mm] greater than L₁.

MOUNTING

Square Mount (4 Holes)

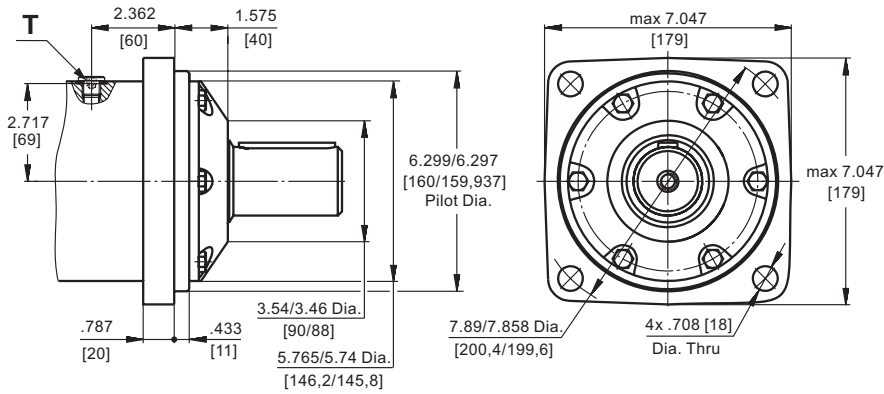

C Mount

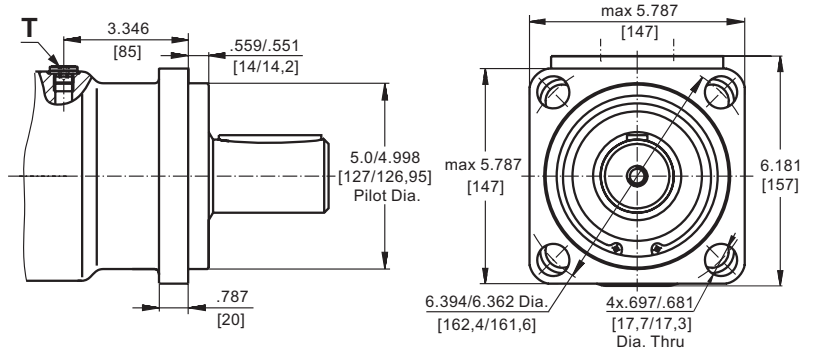

W Wheel Mount

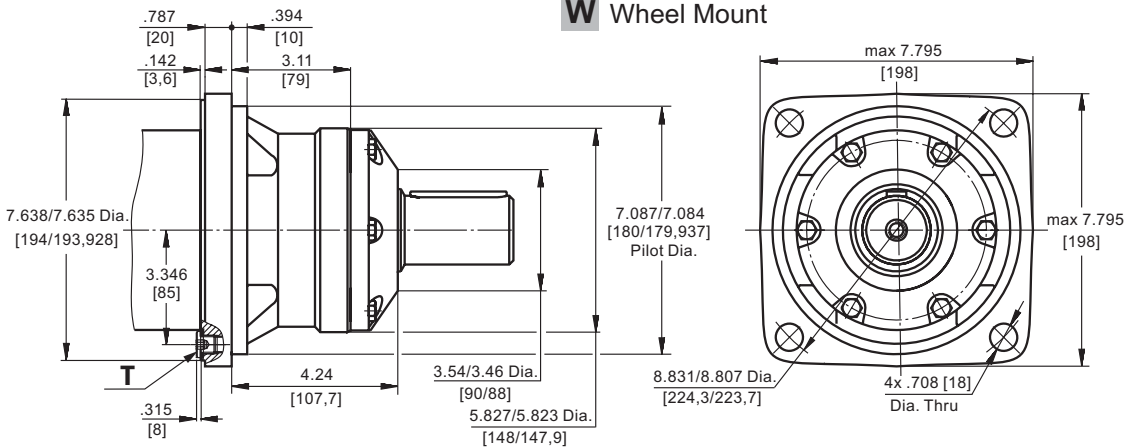

PORTS

Version 2

Version 4

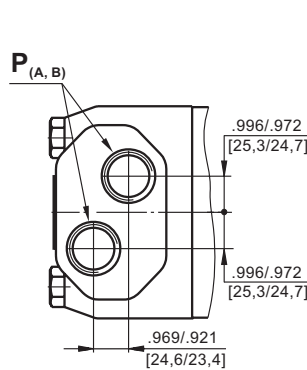
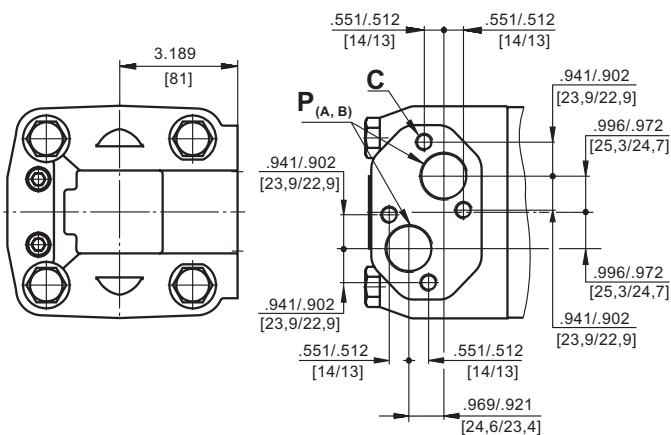

Standard Rotation
Viewed from Shaft End
Port A Pressurized - CW
Port B Pressurized - CCW

Reverse Rotation
Viewed from Shaft End
Port A Pressurized - CCW
Port B Pressurized - CW

	Versions	
	2	4
C	4xM12	-
P (A,B)	2xG1	2x1 $\frac{5}{16}$ -12UN
T	G $\frac{1}{4}$	$\frac{9}{16}$ -18UNF



DIMENSIONS AND MOUNTING DATA

S Short Mount

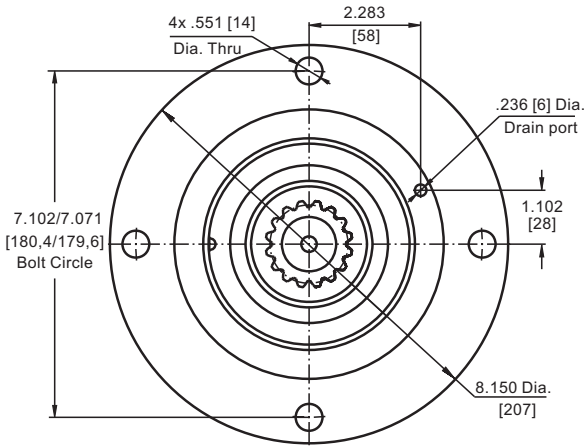

Type	L, in [mm]	L2, in [mm]	*L1, in [mm]
MLHVS 315	6.73[171]	4.61 [117]	.87 [22,0]
MLHVS 400	7.05[179]	4.88 [124]	1.14 [29,0]
MLHVS 500	7.32[186]	5.20 [132]	1.46 [37,0]
MLHVS 630	7.76[197]	5.63 [143]	1.87 [47,5]
MLHVS 800	8.31[211]	6.18 [157]	2.42 [61,5]

* The width of the gerolor is .157 in [4 mm] greater than L1.

	Versions	
	2	4
C	4xM12	-
P (A,B)	2xG1	2x1 ⁵ / ₁₆ -12UN
T	G ¹ / ₄	9 ¹⁶ / ₁₆ -18UNF

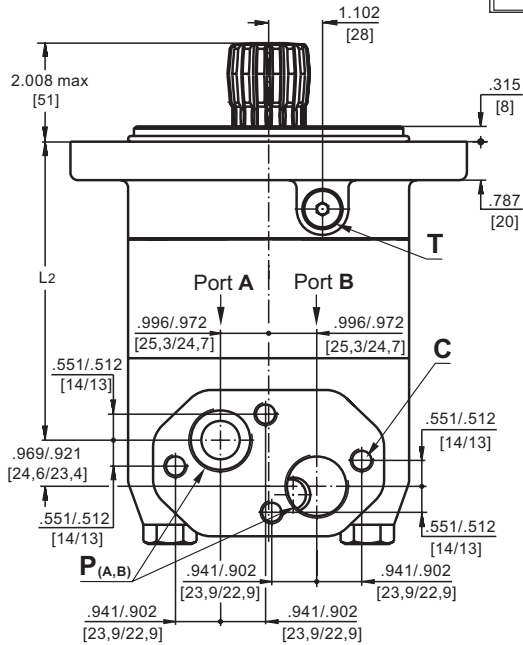
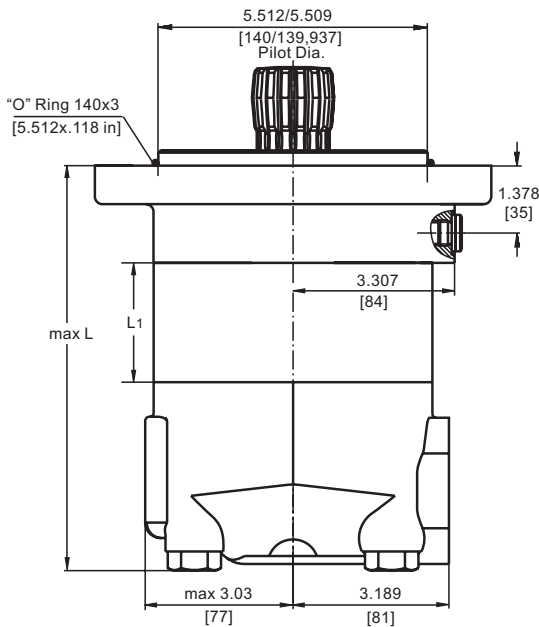

Standard Rotation
Viewed from Shaft End
Port A Pressurized - CW
Port B Pressurized - CCW

Reverse Rotation
Viewed from Shaft End
Port A Pressurized - CCW
Port B Pressurized - CW

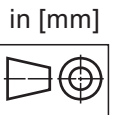

DIMENSIONS OF THE ATTACHED COMPONENT

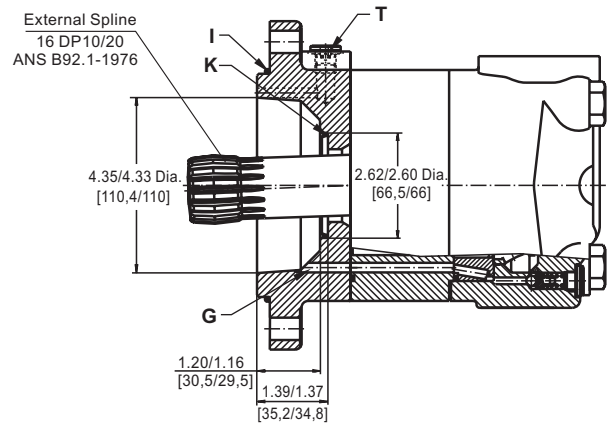
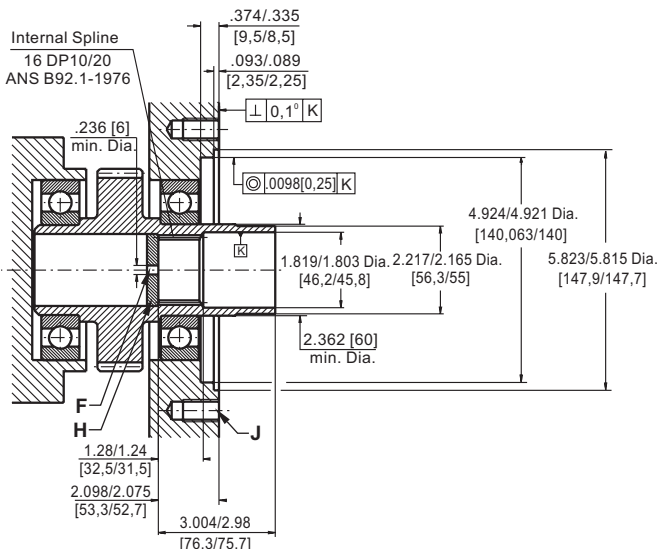

F: Oil circulation hole
G: Internal drain channel
H: Hardened stop plate

I: O- Ring 5.512x.118 [140x3]
J: 4x1/2UN; .71 [18] Deep, 90°, 7.087 [180] Dia. B. C.
K: Conical seal ring
T: Drain connection G1/4 or 9/16 - 18UNF

DIMENSIONS AND MOUNTING DATA

V Very Short Mount

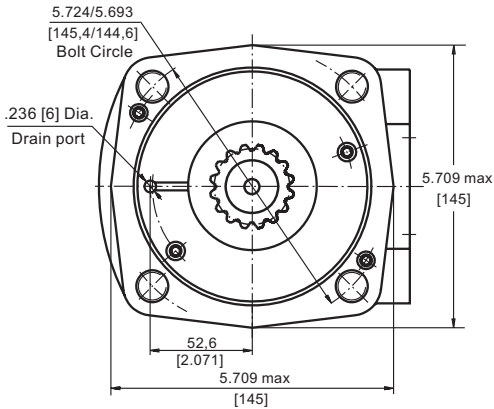

Type	L, in. [mm]	L2, in. [mm]	L3, in. [mm]	*L1, in. [mm]
MLHV 315	4.78 [121,5]	2.68 [68]	1.16 [29,5]	.87 [22,0]
MLHV 400	5.06 [128,5]	2.95 [75]	1.28 [32,5]	1.14 [29,0]
MLHV 500	5.37 [136,5]	3.27 [83]	1.36 [34,5]	1.46 [37,0]
MLHV 630	5.79 [147,0]	3.66 [93]	1.34 [34,0]	1.87 [47,5]
MLHV 800	6.34 [161,0]	4.23 [107,5]	1.18 [30,0]	2.42 [61,5]

* The width of the gerolator is .157 in. [4 mm] greater than L₁.

	Versions	
	2	4
C	4xM12	-
P (A,B)	2xG1	2x1 ⁵ / ₁₆ -12UN

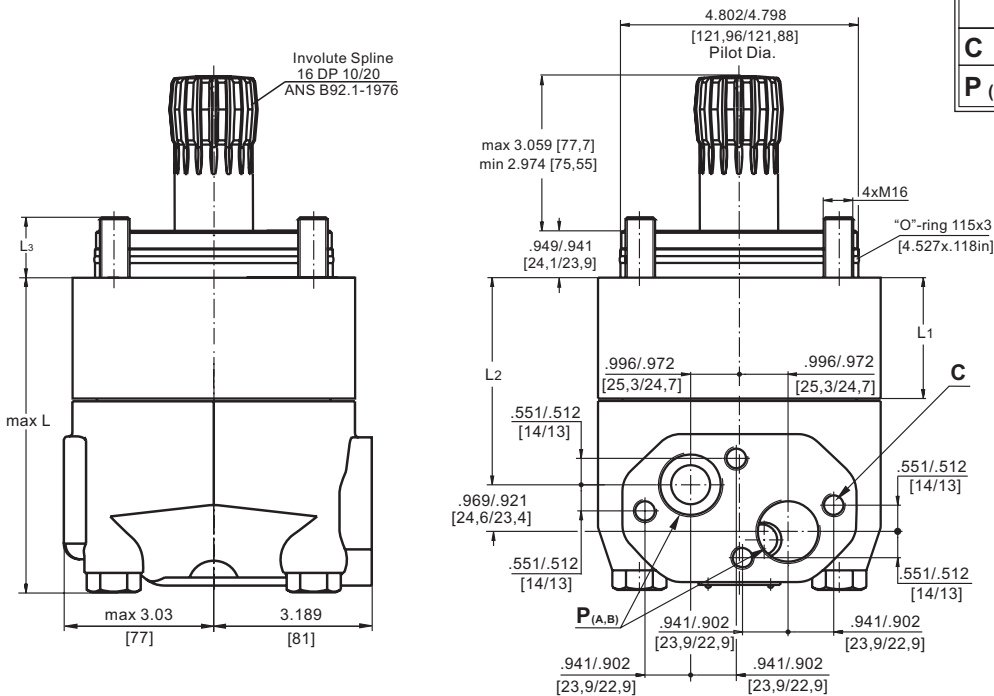

Standard Rotation
Viewed from Shaft End
Port A Pressurized - CW
Port B Pressurized - CCW

Reverse Rotation
Viewed from Shaft End
Port A Pressurized - CCW
Port B Pressurized - CW

in [mm]

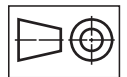

DIMENSIONS OF THE ATTACHED COMPONENT

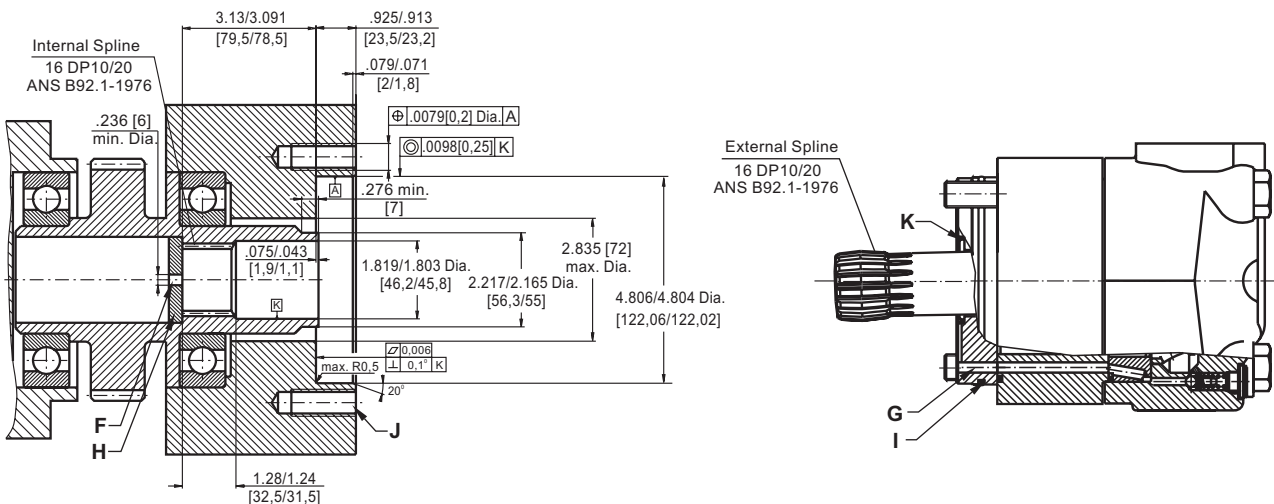

F: Oil circulation hole
G: Internal drain channel
H: Hardened stop plate

I: O- Ring 4.528x.118 [115x3mm]
J: 4xM16; 1.42 [36] Deep, 90°, 5.709 [145] Dia. B. C.
K: Conical seal ring

DRAIN CONNECTION

A drain line has to be used when pressure in the return line can exceed the permissible pressure. It can be connected:
 - For MLHVS at the drain port of the motor;
 - For MLHVV at the drain connection of the attached component. The maximum pressure in the drain line is limited by the attached component and its shaft seal.

The drain line must be possible for oil to flow freely between motor and attached component and must be led to the tank. The maximum pressure in the drain line is limited by the attached component and its seal.

INTERNAL SPLINE DATA FOR THE ATTACHED COMPONENT

Standard ANS B92.1-1976, class 5
 [m=2.54; corrected x.m=1]

Fillet Root Side Fit		inch	mm
Number of Teeth	z	16	16
Diametral Pitch	DP	10/20	10/20
Pressure Angle		30°	30°
Pitch Dia.	D	1.6	40,640
Major Dia.	D _{ri}	1.796±1.780	45,2 ^{+0,4}
Minor Dia.	D _i	1.5175±1.516	38,5 ^{+0,039}
Space Width [Circular]	L _o	.2055±.2025	5,18±0,037
Fillet Radius	R	.015	0,4
Max. Measurement between Pins	L	1.284±1.278	32,47 ^{+0,15}
Pin Dia.	d	.22051±.22043	5,6±0,001

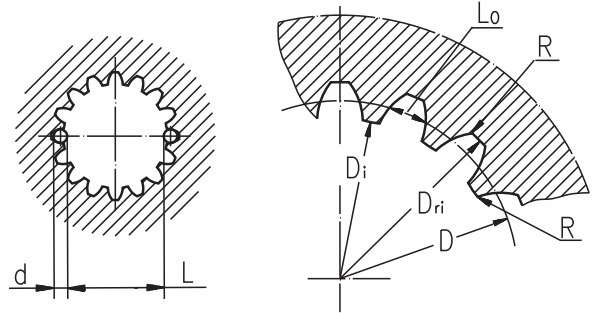

Hardening Specification:
 HV=750±50 on the surface.
 HV=560 at .035-.019 [0,7±0,2] case depth
 Material: 20 MoCr4 DIN 17210 or SAE8620.

MOTOR WITH TACHO CONNECTION

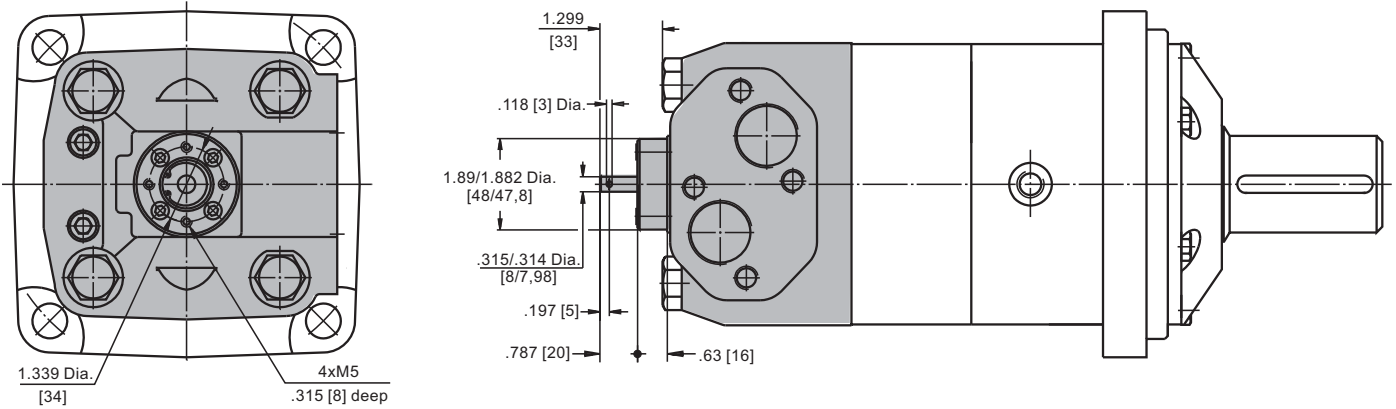

MAX. PERMISSIBLE SHAFT SEAL PRESSURE

Max. return pressure without drain line or max. pressure in the drain line

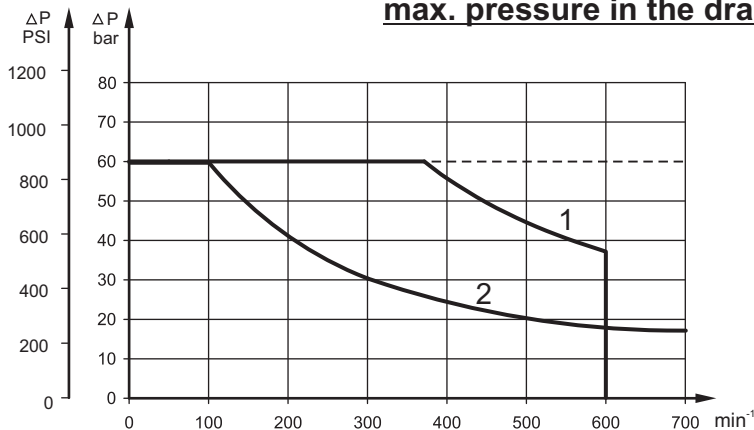

- 1: Drawing for High Pressure Seal ("U" Seal)
- 2: Drawing for Standard Shaft Seal

— - continuous operations
 - - - - intermittent operations

SHAFT EXTENSIONS

C

2 1/4" [57,15] straight, Parallel key 1/2 "x 1/2" x 2 1/4" BS46

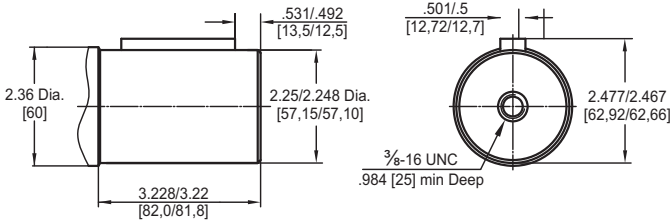

B

2 1/4" [57,15] straight, Parallel key 1/2 "x 1/2" x 2 1/4" BS46

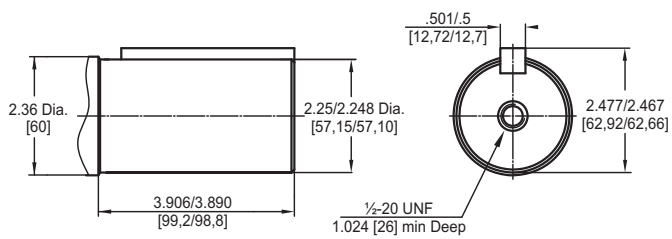

M

ø50 straight, Parallel key A14x9x70 DIN 6885

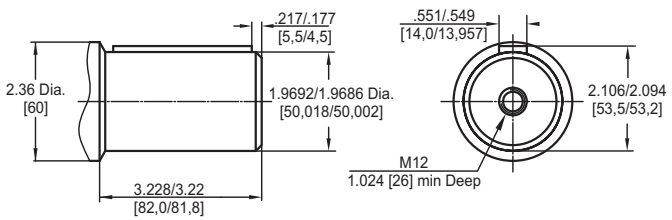

G

16T Splined, 2 1/8" [53,975] ANS B92.1-1976

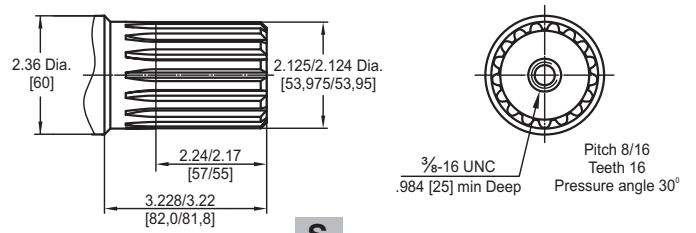

S

16T Splined, 2 1/8" [53,975] ANS B92.1-1976

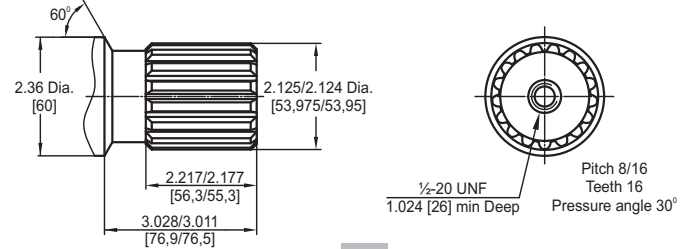

T

2 1/4" [57,15] SAE J501 Tapered 1:8
Parallel key 9/16 "x 9/16 "x 2" BS46

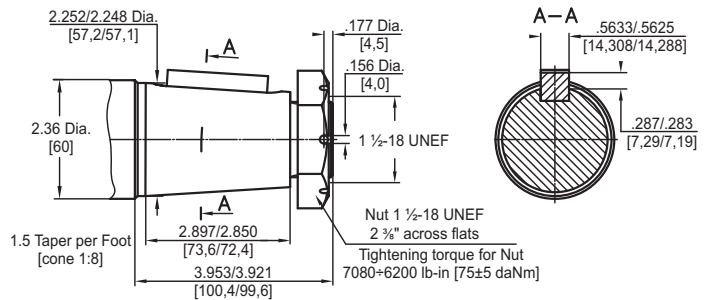

ORDER CODE



1	2	3	4	5	6	7
MLHV						

Pos.1 - Mounting Flange

- omit - Square, 4 holes
- C** - C Flange, 4 holes
- W** - Wheel mount
- S** - Short
- V** - Very short

Pos.2 - Displacement code

- 315** - 19.18 [314,5] in³/rev [cm³/rev]
- 400** - 24.45 [400,9] in³/rev [cm³/rev]
- 500** - 30.48 [499,6] in³/rev [cm³/rev]
- 630** - 38.38 [629,1] in³/rev [cm³/rev]
- 800** - 48.91 [801,8] in³/rev [cm³/rev]

Pos.3 - Shaft Extensions

- omit - for **S** and **V** mounting flange
- C** - 2 1/4" [57,15] straight, Parallel key
- B** - 2 1/4" [57,15] straight, Parallel key
- M** - 50 mm straight, Parallel key
- G** - 2 1/8" [53,975] 16T Splined
- S** - 2 1/8" [53,975] 16T Splined
- T** - 2 1/4" [57,15] SAE J501 Tapered

Pos.4 - Port Size/Type [standard manifold to each]

- 2** - side ports, 2xG1, G 1/4, BSP thread, ISO 228
- 4** - side ports, 2x1 1/16-12 UN, O-ring, 3/16-18 UNF

Pos.5 - Shaft Seal Version [see page 49]

- omit - Low pressure shaft seal
- U** - High pressure shaft seal

Pos.6 - Special Features [see page 51]

Pos.7 - Design Series

- omit - Factory specified

The hydraulic motors are mangano-phosphatized as standard.

MOTOR SPECIAL FEATURES

Special Feature Description	Order Code	Motor type		
		MLHS	MLHT	MLHV
Speed Sensor*	RS	O	O	O
Tacho Connection**	T	O	O	O
Reinforced motor	HD	-	O	O
Low Leakage	LL	O	O	O
Low Speed Valving	LSV	O	O	O
Reverse Rotation	R	O	O	O
Paint***	P	O	O	O
Corrosion Protected Paint***	PC	O	O	O
Check Valves		S	S****	S****

- O** Optional
- Not applicable
- S** Standard

* for sensor ordering see pages 52-53.
 ** only for side ports.
 *** color at customer's request.
 ****without check valves for "HD" option.

△ For more information about HD option please contact with "M+S Hydraulic".

MOTORS WITH SPEED SENSOR

MLHS...RS

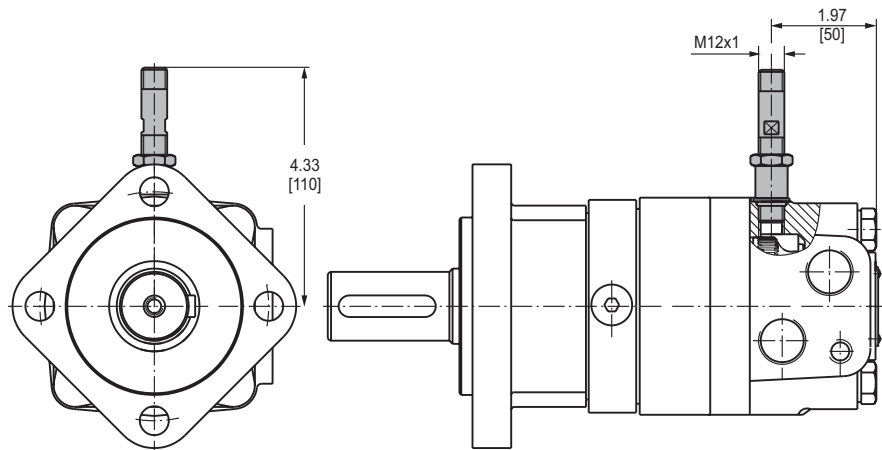

MLHT...RS

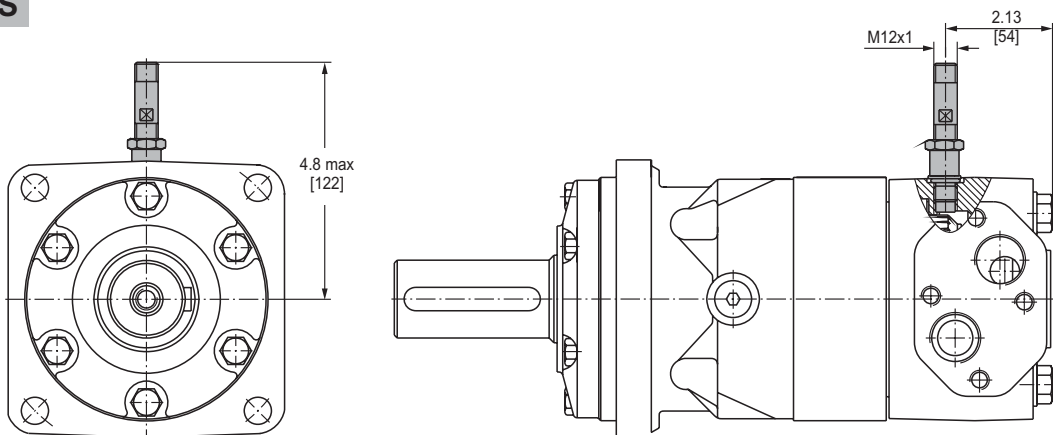

MLHV...RS

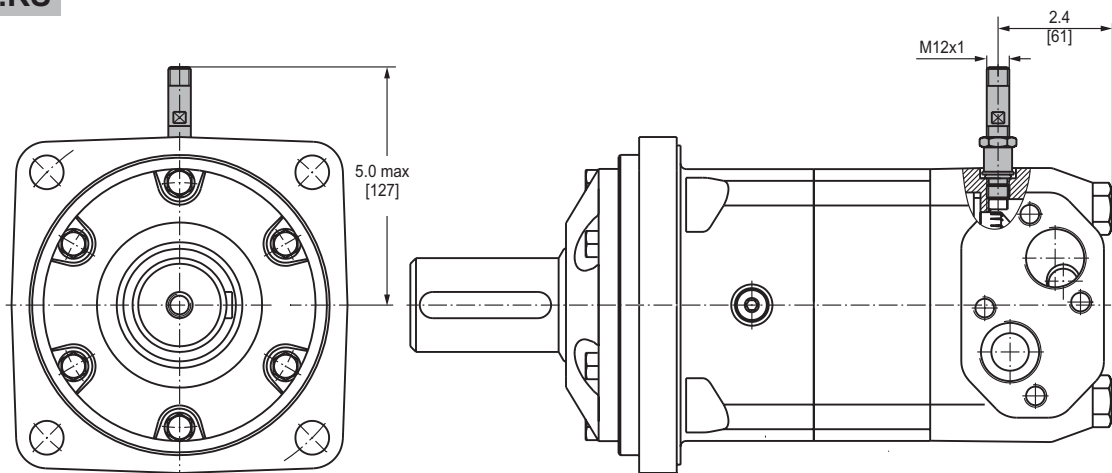

TECHNICAL DATA OF THE SPEED SENSOR

Technical data

Frequency range	0...15 000 Hz
Output	PNP, NPN
Power supply	10...36 VDC
Current input	20 mA (@24 VDC)
Ambient Temperature	-40...+257°F [-40...+125°C]
Protection	IP 67
Plug connector	M12-Series
Mounting principle	ISO 6149

Output signal

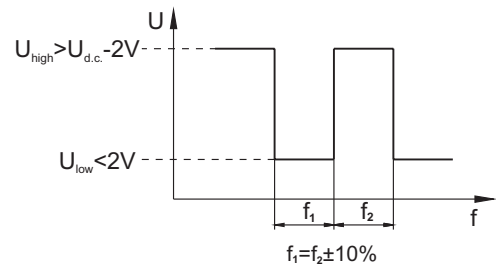

Load max.: $I_{high} = I_{low} < 50\text{mA}$

Motor type	MLHS	MLHT	MLHV
Pulses per revolution	54	84	102

Wiring diagrams

PNP

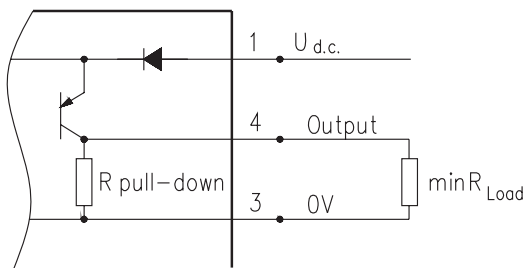

NPN

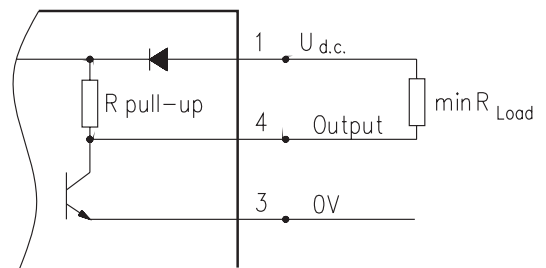

$$R_{Load} [k\Omega] = U_{d.c.} [V] / I_{max} [mA]$$

Stick type

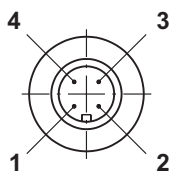

Terminal No.	Connection	Cable Output
1	$U_{d.c.}$	Brown
2	No connection	White
3	0V	Blue
4	Output signal	Black

Order Code for Speed Sensor

Sensor Code	Output type	Electric connection
RSN	NPN	Connector BINDER 713 series
RSP	PNP	Connector BINDER 713 series
RSNL5	NPN	Cable output 3x0,25; 196 in [5m] long
RSPL5	PNP	Cable output 3x0,25; 196 in [5m] long

NOTE: *- The speed sensor is not fitted at the factory, but is supplied in a plastic bag with the motor. For installation see enclosed instructions.

APPLICATION CALCULATION

VEHICLE DRIVE CALCULATIONS

1. Motor speed: n, RPM

$$n = \frac{168 \times v_{mi} \times i}{R_m} \quad n = \frac{2,65 \times v_{km} \times i}{R_m}$$

v_{km} - vehicle speed, km/h;

v_{mi} - vehicle speed, mile/h;

R_m - wheel rolling radius, m;

R_{in} - wheel rolling radius, in;

i - gear ratio between motor and wheels.

If no gearbox, use $i=1$.

2. Rolling resistance: RR, lbs [daN]

The resistance force resulted in wheels contact with different surfaces:

$$RR = G \times \rho$$

G - total weight loaded on vehicle, lbs [daN];

ρ - rolling resistance coefficient (Table 1).

Table 1

Rolling resistance coefficient In case of rubber tire rolling on different surfaces	
Surface	ρ
Concrete- faultless	0.010
Concrete- good	0.015
Concrete- bad	0.020
Asphalt- faultless	0.012
Asphalt- good	0.017
Asphalt- bad	0.022
Macadam- faultless	0.015
Macadam- good	0.022
Macadam- bad	0.037
Snow- 5 cm	0.025
Snow- 10 cm	0.037
Polluted covering- smooth	0.025
Polluted covering- sandy	0.040
Mud	0.037÷0.150
Sand- Gravel	0.060÷0.150
Sand- loose	0.160÷0.300

3. Grade resistance: GR, lbs [daN]

$$GR = G \times (\sin \alpha + \rho \times \cos \alpha)$$

α - gradient negotiation angle (Table 2)

Table 2

Grade %	α Degrees	Grade %	α Degrees
1%	0° 35'	12%	6° 5'
2%	1° 9'	15%	8° 31'
5%	2° 51'	20%	11° 19'
6%	3° 26'	25%	14° 3'
8%	4° 35'	32%	18°
10%	5° 43'	60%	31°

4. Acceleration force: FA, lbs [daN]

Force FA necessary for acceleration from 0 to maximum speed v and time t can be calculated with a formula:

$$FA = \frac{v_{mi} \times G}{22 \times t}, [\text{lbs}]; \quad FA = \frac{v_{km} \times G}{3,6 \times t}, [\text{daN}]$$

FA - acceleration force, lbs [daN];

t - time, [s].

5. Tractive effort: DP, lbs [daN]

Tractive effort DP is the additional force of trailer. This value will be established as follows:

-acc.to constructor's assessment;

-as calculating forces in items 2, 3 and 4 of trailer; the calculated sum corresponds to the tractive effort requested.

6. Total tractive effort: TE, lbs [daN]

Total tractive effort TE is total effort necessary for vehicle motion; that the sum of forces calculated in items from 2 to 5 and increased with 10 % because of air resistance.

$$TE = 1,1 \times (RR + GR + FA + DP)$$

RR - force acquired to overcome the rolling resistance;

GR - force acquired to slope upwards;

FA - force acquired to accelerate (acceleration force);

DP - additional tractive effort (trailer).

7. Motor Torque moment: M, lb-in [daNm]

Necessary torque moment for every hydraulic motor:

$$M = \frac{TE \times R_{in} [R_m]}{N \times i \times \eta_M}$$

N - motor numbers;

η_M - mechanical gear efficiency (if it is available).

8. Cohesion between tire and road covering: M_w , lb-in [daNm]

$$M_w = \frac{G_w \times f \times R_{in} [R_m]}{i \times \eta_M}$$

To avoid wheel slipping, the following condition should be observed $M_w > M$

f - frictional factor;

G_w - total weight over the wheels, lbs [daN].

Table 3

Surface	Frictional factor f
Steel on steel	0.15 ÷ 0.20
Rubber tire on polluted surface	0.5 ÷ 0.7
Rubber tire on asphalt	0.8 ÷ 1.0
Rubber tire on concrete	0.8 ÷ 1.0
Rubber tire on grass	0.4

9.Radial motor loading: P_{rad} , lbs [daN]

When motor is used for vehicle motion with wheels mounted directly on motor shaft, the total radial loading of motor shaft P_{rad} is a sum of motion force and weight force acting on one wheel.

- G_w - Weight held by wheel;
- P_{rad} - Total radial loading of motor shaft;
- M/R - Motion force.

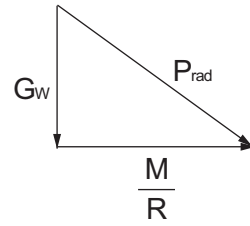

$$P_{rad} = \sqrt{G_w^2 + \left(\frac{M}{R}\right)^2}$$

In accordance with calculated loadings the suitable motor from the catalogue is selected.

DRAINAGE SPACE AND DRAINAGE PRESSURE

Advantages in oil drainage from drain space: Cleaning; Cooling and Seal lifetime prolonging.

