

HYDROSTATIC TRANSMISSION FOR TRUCK MIXERS

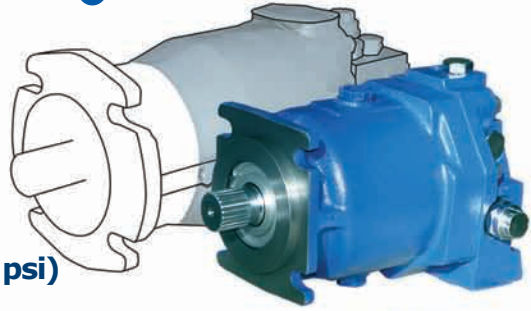

ADVANTAGES OF TRUCK MIXER MOTOR:

- Increased power
- Higher rotating torque
- Rated pressure up to 420 bar (6090 psi)
- Smaller size
- Reduced weight



Using a hydrostatic transmission you get:

- high rotating torque at relatively small size;
- ramp up to full power immediately after start-up;
- stepless speed and torque control;
- overload protection;
- wide range of speed control.



PUMP CIRCUIT

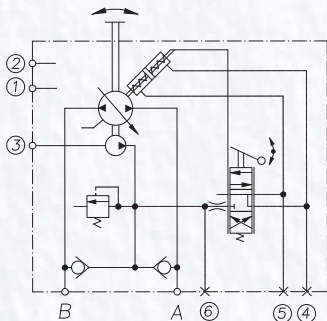

TECHNICAL INFORMATION. PUMPS

Displacement Code		71	90
Displacement, max.	in ³ /ccm	4,25 / 69,8	5,43 / 89
Maximum Flow	gpm/l/min	49,14 / 186,3	57,58 / 218,9
Maximum Pressure in High Pressure Line	psi/bar	6090 / 420	6090 / 420
Maximum Case Pressure	psi/bar	36,25 / 2,5	
Maximum Speed	rpm	2810	2590
Minimum Speed	rpm	500	
Maximum Swashplate Angle	Degr	±18	
Weight (without fluid)	lb/kg	139 / 63	172 / 78
Rated Power	hp/kW	212,2 / 156	248,9 / 183

TECHNICAL INFORMATION. MOTORS



MOTOR CIRCUIT

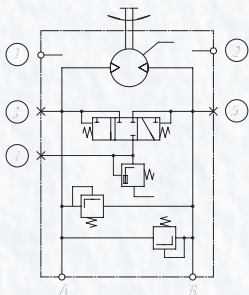

Displacement Code		71	90
Displacement	in ³ /ccm	4,25 / 69,8	5,43 / 89
Maximum Pressure in High Pressure Line	psi/bar	6090 / 420	6090 / 420
Maximum Case Pressure	psi/bar	36,25 / 2,5	
Maximum Rotating Torque	lb-in/Nm	3920 / 443	5000 / 565
Maximum Speed	rpm	2900	2900
Minimum Speed	rpm	500	
Rated Speed	rpm	2500	
Rated Power	hp/kW	99,2 / 134	127,3 / 172
Weight (without fluid)	lb/kg	77 / 35	77 / 35

EXAMPLE OF TRUCK MIXERS HYDRAULIC SYSTEM

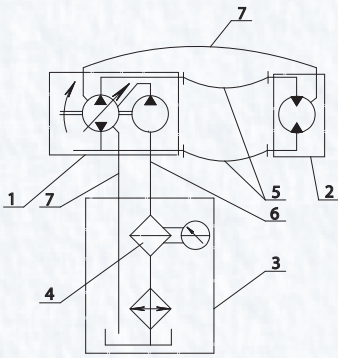

1. Variable Displacement Pump
2. Fixed Displacement Motor
3. Oil cooler and oil tank
4. Suction Filter

5. High Pressure Hoses
6. Charge Pump Hoses
7. Drain Hoses

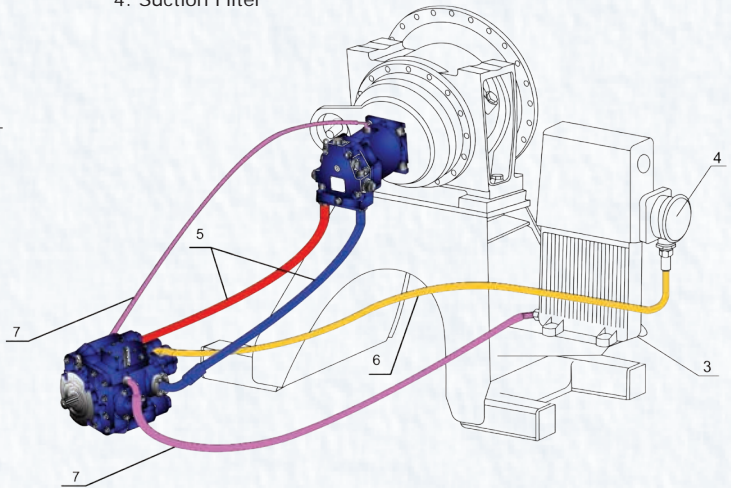

FIXED DISPLACEMENT AXIAL-PISTON MOTOR MF71/3... MF90/3...

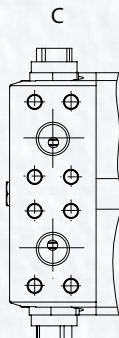
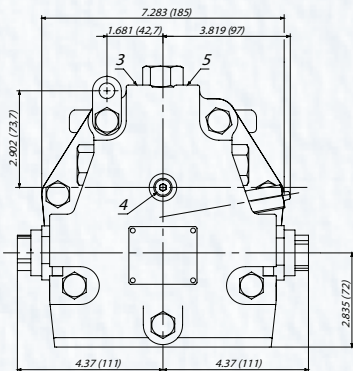
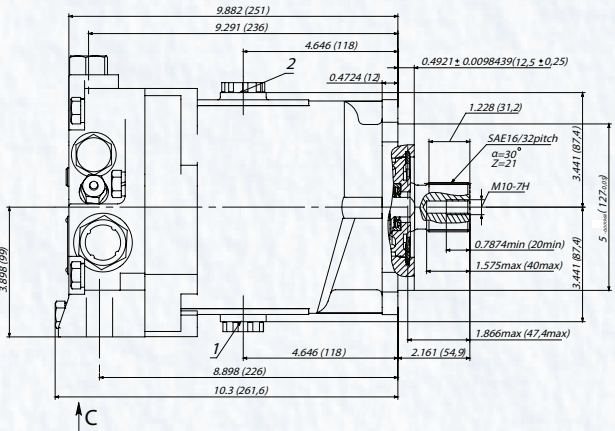
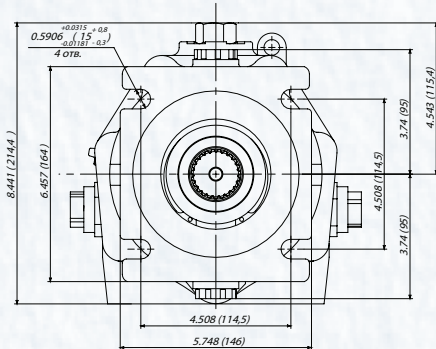

Framesize	Ports	
	«1»; «2»	«3»; «4»; «5»
71	7/8-14UNF-2B	7/16-20UNF-2B
90		

VARIABLE DISPLACEMENT AXIAL-PISTON PUMP PV71/1... PV90/1...

SHUFFT OPTIONS. PUMP & MOTOR

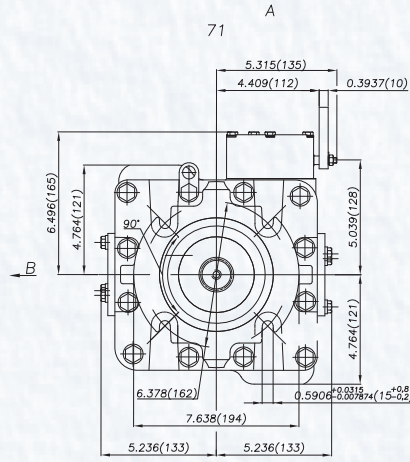
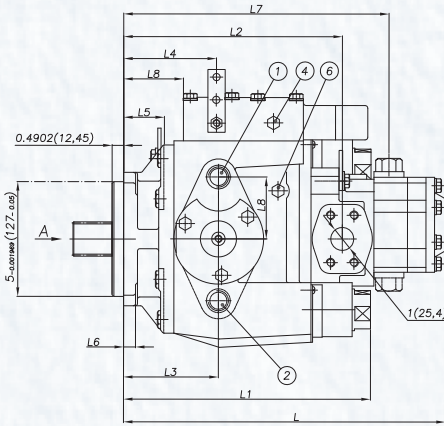

Right Hand Rotation ← Left Hand Rotation

